

Anthony 24F Glulam

Architectural, Industrial &
Framing Applications

Anthony Power Column™

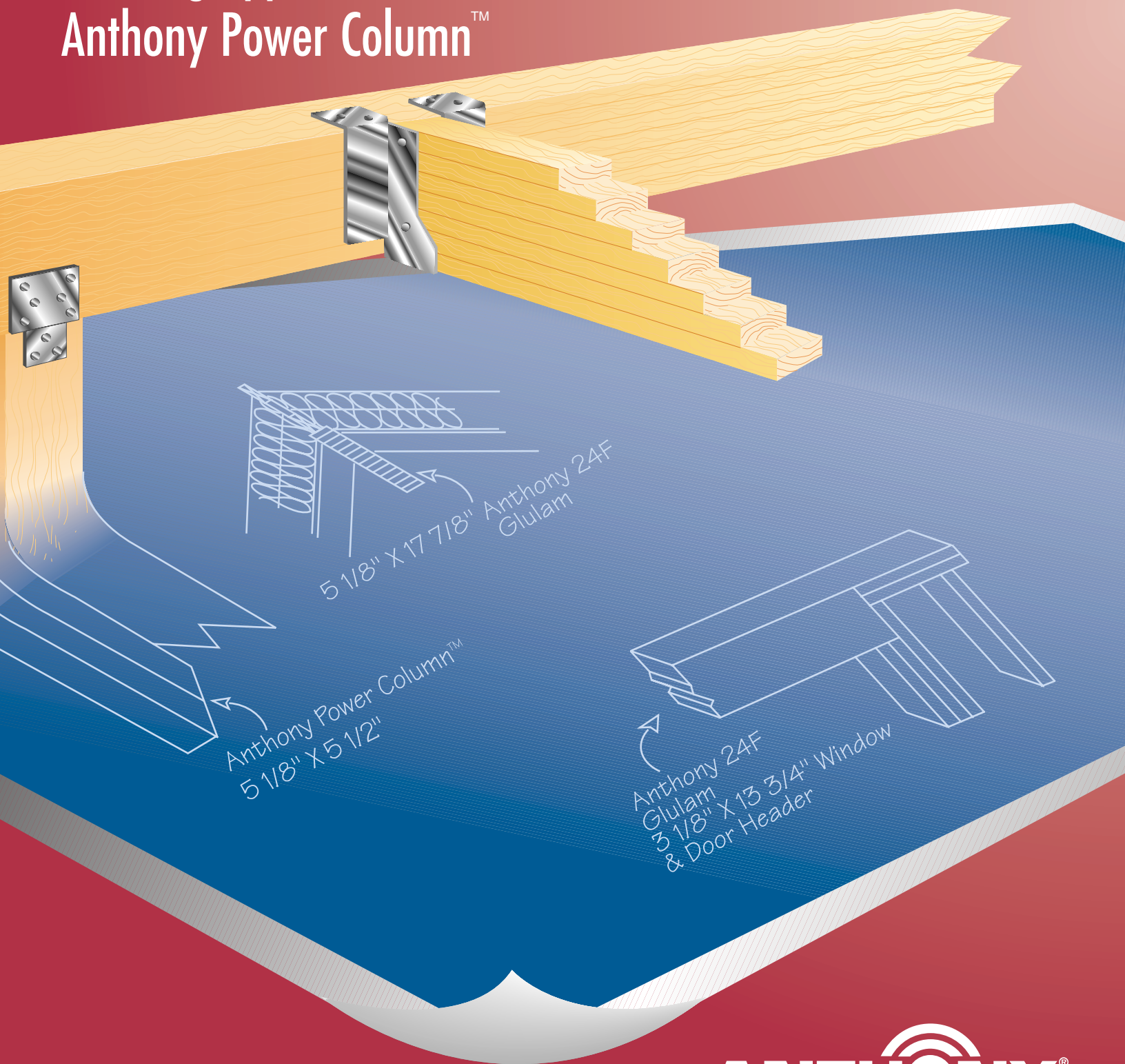

Beam, Header and Column Tables



Anthony 24F Glulam Advantages

- ◆ Economical Beam & Header
- ◆ Architectural, Industrial & Framing Grades
- ◆ No nail laminating necessary
- ◆ Flexibility in design & installation
- ◆ Cambered or non-cambered

- ◆ Design stresses 2400Fb - 1.8E - 270Fv
- ◆ 3 1/8", 3 1/2", 5 1/8", 5 1/2", 6 3/4", and 8 3/4" width
- ◆ Lighter than steel, LVL, and PSL
- ◆ Renewable resource
- ◆ Individually wrapped

The Anthony 24F Glulam is a glued laminated beam and header used where reliable engineered wood applications are required. It is an economical alternative to LVL and PSL in many standard structural applications where the high strength and



stiffness values are not really needed. Anthony's 24F Glulam is readily available through stocking dealers. The 3-1/2" and 5-1/2" widths are available which readily match 2x4 and 2x6 wall framing. The Anthony 24F Glulam uses only readily-available Southern pine lumber, recognized through extensive testing as the strongest lumber resource available.

To enhance Anthony 24F Glulam quality further, all outer laminations have strict quality control procedures. Each beam has a specific lumber lay-up combination which optimizes Glulam performance. The highest strength lumber is placed in the tension and compression zones, efficiently and optimally using lumber resources.

The Anthony 24F Glulam can be used for window, door and garage door headers, floor edge and center girder beams, roof ridge beams, and commercial beams and purlins.

Features

Dimensional Stability: Glulam is a laminated composite product of high-strength lumber. This randomizes any natural defects so there is greater beam strength and a higher degree of reliability. There is also less likelihood of warping, twisting, checking, cupping or shrinking.

Moisture Control: Anthony Glulam consistently averages 12% moisture, which is near equilibrium moisture content.

Building Code Evaluations: Adopted under all major material building codes.

Fire Performance: Glulam falls into the building code category of heavy timber, and therefore has excellent fire performance.

Quality Assurance: Glulam is manufactured in accordance with ANSI/AITC A190.1-1992 (Structural Glued Laminated Timber). Plant implemented Total Quality Management, statistical process control procedures and AITC as our quality assurance program ensure consistent quality and performance in every Glulam.

About Anthony Forest Products Company

Anthony Forest Products is a completely integrated forest products company incorporated in 1965, and begun in 1916. The company owns approximately 73,000 acres of timberland in Arkansas, Louisiana, and Texas, and operates southern pine lumber producing mills in Urbana, Arkansas, and Atlanta, Texas; and wood chip mills in Plain Dealing, Louisiana, and Troup, Texas. The company also operates an engineered wood laminating plant in El Dorado, Arkansas and Washington, Georgia.

Our History:

Headquartered in El Dorado, Arkansas, Anthony Forest has made some dramatic changes to position itself for the 21st Century. This vision could not have been accomplished without the four generations of forest products experience passed down through the family.

The company has applied its policy of environmental protection to its timberlands through adherence to Sustainable Forestry Initiative through the American Forest and Paper Association. Our land managers have received extensive training in the protection of threatened and endangered species, which may be encountered on the lands. We are committed to being a prudent steward of our lands through the next century.

Our two laminating plants make us the largest southern pine glued-laminated timber manufacturer in the USA. We have 35 years of solid experience in engineered wood products, which include the Power Beam®, Power Header®, Power Log®, Power Column™, Power Plank, 1.6 E Short Span Header and custom laminated products.

Table of Contents

Glulam AdvantagesPg 1	Allowable Roof Load TablesPg 12 LDF=1.25 3 1/2" and 5 1/2"	Guidelines for DrillingPg 22 Horizontal Holes
Anthony Forest HistoryPg 2	Allowable Floor Load TablesPg 13 LDF=1.00 6 3/4"	Vertical 1/2" Diameter HolesPg 23 Glulam Beams
Performance Comparison Tables . .Pg 3	Allowable Roof Load TablesPg 14 LDF=1.15 6 3/4"	Notching Equations forPg 24 Anthony Glulam
Design PropertiesPg 4	Allowable Roof Load TablesPg 15 LDF=1.25 6 3/4"	Standard Radius or CurvaturePg 25 (feet)
Window, Door and Garage Door . .Pg 5 Headers – Single Story	Allowable Floor Load TablesPg 16 LDF=1.00 8 3/4"	Anthony Power Column™Pg 26
Window, Door and Garage Door . .Pg 6 Headers – Single Story (cont.)	Allowable Roof Load TablesPg 17 LDF=1.15 8 3/4"	Anthony Power Column™Pg 27 Combinations #50
Allowable Floor Load TablesPg 7 LDF=1.00 3 1/8" and 5 1/8"	Allowable Roof Load TablesPg 18 LDF=1.25 8 3/4"	Engineered TimbersPg 28
Allowable Roof Load TablesPg 8 LDF=1.15 3 1/8" and 5 1/8"	Load Table NotationsPg 19 and Examples	Power Products StoragePg 29 Protection & Handling Instructions
Allowable Roof Load TablesPg 9 LDF=1.25 3 1/8" and 5 1/8"	Load Table ExamplesPg 20	Power Products CertificatePg 30 of Warranty
Allowable Roof Load TablesPg 10 LDF=1.00 3 1/2" and 5 1/2"	Connection DetailsPg 21	
Allowable Roof Load TablesPg 11 LDF=1.15 3 1/2" and 5 1/2"		

Performance Comparison Tables

3-1/8" & 5-1/8" Widths - Standard Depths

Glulam Conversions						
Clear Span	Allowable PLF Load (LL/TL)	Beam Application	Anthony 24F Glulam	Multiple Lumber #1 SYP ¹	Multiple Lumber #1 DF-L ²	Timbers #1 DF-L ³
8'	600/900	Floor	3-1/8 x 9-5/8	3 ply - 2 x 12	3 ply - 2 x 12	6 x 12, 8 x 10
16'	450/650	Floor	5-1/8 x 12-3/8	6 ply - 2 x 12	8 ply - 2 x 12	8 x 14, 12 x 12
24'	110/170	Floor	3-1/8 x 13-3/4	4 ply - 2 x 12	5 ply - 2 x 12	6 x 14, 8 x 12
8'	2400/2400	Roof (1.15)	3-1/8 x 13-3/4	5 ply - 2 x 12	6 ply - 2 x 12	10 x 14, 12 x 12
16'	550/760	Roof (1.15)	5-1/8 x 12-3/8	6 ply - 2 x 12	8 ply - 2 x 12	8 x 14, 12 x 12
18'	480/640	Roof (1.15)	5-1/8 x 12-3/8	7 ply - 2 x 12	8 ply - 2 x 12	8 x 14, 12 x 12
Clear Span	Allowable PLF Load (LL/TL)	Beam Application	Anthony 30F Glulam (30F _b -2.1E-290F _v)	LVL ⁴	PSL ⁵	Steel ⁶ 36 ksi
8'	600/900	Floor	3-1/2 x 7-1/4	2 ply - 1-3/4 x 7-1/4	3-1/2 x 7-1/4	W6 x 9, W8 x 10
16'	450/650	Floor	5-1/2 x 11-1/4	3 ply - 1-3/4 x 11-7/8	5-1/4 x 11-7/8	W10 x 12, W8 x 15
24'	110/170	Floor	3-1/2 x 14	2 ply - 1-3/4 x 14	3-1/2 x 14	W10 x 12, W12 x 14
8'	2400/2400	Roof (1.15)	3-1/2 x 11-1/4	2 ply - 1-3/4 x 11-7/8	3-1/2 x 11-7/8	W10 x 12, W8 x 13
16'	550/760	Roof (1.15)	5-1/2 x 11-1/4	3 ply - 1-3/4 x 11-1/4	5-1/4 x 11-1/4	W10 x 15, W12 x 14
18'	480/640	Roof (1.15)	5-1/2 x 11-1/4	3 ply - 1-3/4 x 11-7/8	5-1/4 x 11-7/8	W10 x 15, W12 x 14

Performance Comparison Tables

3-1/2" & 5-1/2" Widths - Standard Depths

Glulam Conversions						
Clear Span	Allowable PLF Load (LL/TL)	Beam Application	Anthony 24F Glulam	Multiple Lumber #1 SYP ¹	Multiple Lumber #1 DF-L ²	Timbers #1 DF-L ³
8'	600/900	Floor	3-1/2 x 8-1/4	3 ply - 2 x 12	3 ply - 2 x 12	6 x 12, 8 x 10
16'	450/650	Floor	5-1/2 x 12-3/8	6 ply - 2 x 12	8 ply - 2 x 12	8 x 14, 12 x 12
24'	110/170	Floor	3-1/2 x 13-3/4	4 ply - 2 x 12	5 ply - 2 x 12	6 x 14, 8 x 12
8'	2400/2400	Roof (1.15)	3-1/2 x 13-3/4	5 ply - 2 x 12	6 ply - 2 x 12	10 x 14, 12 x 12
16'	550/760	Roof (1.15)	5-1/2 x 11	6 ply - 2 x 12	8 ply - 2 x 12	8 x 14, 12 x 12
18'	480/640	Roof (1.15)	5-1/2 x 12-3/8	7 ply - 2 x 12	8 ply - 2 x 12	8 x 14, 12 x 12
Clear Span	Allowable PLF Load (LL/TL)	Beam Application	Anthony 30F Glulam (30F _b -2.1E-290F _v)	LVL ⁴	PSL ⁵	Steel ⁶ 36 ksi
8'	600/900	Floor	3-1/2 x 7-1/4	2 ply - 1-3/4 x 7-1/4	3-1/2 x 7-1/4	W6 x 9, W8 x 10
16'	450/650	Floor	5-1/2 x 11-1/4	3 ply - 1-3/4 x 11-7/8	5-1/4 x 11-7/8	W10 x 12, W8 x 15
24'	110/170	Floor	3-1/2 x 14	2 ply - 1-3/4 x 14	3-1/2 x 14	W10 x 12, W12 x 14
8'	2400/2400	Roof (1.15)	3-1/2 x 11-1/4	2 ply - 1-3/4 x 11-7/8	3-1/2 x 11-7/8	W10 x 12, W8 x 13
16'	550/760	Roof (1.15)	5-1/2 x 11-1/4	3 ply - 1-3/4 x 11-1/4	5-1/4 x 11-1/4	W10 x 15, W12 x 14
18'	480/640	Roof (1.15)	5-1/2 x 11-1/4	3 ply - 1-3/4 x 11-7/8	5-1/4 x 11-7/8	W10 x 15, W12 x 14

Design values used for conversion tables follow:

¹ Southern Pine #1 from National Design Specifications Supplement Table 4B

² Douglas Fir Larch #1 from National Design Specifications Supplement Table 4A

³ Douglas Fir Larch #1 from National Design Specifications Supplement Table 4D

⁴ LVL Design Values: F_b=2925 psi, F_v=285 psi, MOE=2,000,000 psi

⁵ Parallam[®] Design Values: F_b=2900 psi, F_v=290 psi, MOE=2,000,000 psi Parallam[®] is a registered trademark of Trus Joist MacMillian, a Weyerhaeuser business

⁶ Steel Design Values are based on 36 ksi steel using the Seventh Edition of the Steel Construction Manual

Design Properties

24F Glulam Design Properties

Allowable Design Stresses (psi)

Flexural Stress Tension F_b^*	Flexural Stress Compression F_b	Tension Parallel to Grain F_t	Compression Perpendicular to Grain $F_{c\perp}$	Compression Parallel to Grain F_c	Horizontal Shear F_v	Modulus of Elasticity MOE
2400	1950	1150	740	1700	270	1,800,000

*For nominal 12" depths. For other depths:

$$C_v = K_L [(21/L) \times (12/d) \times (5.125/b)] \leq 1.0$$

L = length of member between points of zero moment, ft.

d = depth, of bending member, inches.

b = width, inches for full width members.

K_L = loading coefficient.

SINGLE SPAN BEAM:

Concentrated load at mid span

Uniformly distributed loads

Two equal concentrated loads at 1/3 points of span

CONTINUOUS BEAM OR CANTILEVER:

All loading conditions

$\frac{KL}{L}$

1.09

1.0

0.96

1.0

24F Glulam Section Properties

3-1/8" Glulam

Design Property	STANDARD DEPTHS (in inches)							
	8 1/4	9 5/8	11	12 3/8	13 3/4	15 1/8	16 1/2	17 7/8
Area (in. ²)	26	30	34	39	43	47	52	56
Section Modulus (in. ³)	35	48	63	80	98	119	142	166
Moment of Inertia (in. ⁴)	146	232	347	494	677	901	1170	1487
Weight (lbs/LF)	6.8	7.9	9.1	10.2	11.3	12.5	13.6	14.8

5-1/8" Glulam

Design Property	STANDARD DEPTHS (in inches)										
	11	12 3/8	13 3/4	15 1/8	16 1/2	17 7/8	19 1/4	20 5/8	22	23 3/8	
Area (in. ²)	56	63	70	78	85	92	99	106	113	120	
Section Modulus (in. ³)	103	131	161	195	233	273	317	363	413	467	
Moment of Inertia (in. ⁴)	568	809	1110	1478	1919	2439	3047	3747	4548	5455	
Weight (lbs/LF)	14.9	16.7	18.6	20.5	22.3	24.2	26.1	27.9	29.8	31.6	

3-1/2" Glulam

Design Property	STANDARD DEPTHS (in inches)							
	8 1/4	9 5/8	11	12 3/8	13 3/4	15 1/8	16 1/2	17 7/8
Area (in. ²)	29	34	39	43	48	53	58	63
Section Modulus (in. ³)	40	54	71	89	110	133	159	186
Moment of Inertia (in. ⁴)	164	260	388	553	758	1009	1310	1666
Weight (lbs/LF)	7.6	8.9	10.2	11.4	12.7	14	15.3	16.5

5-1/2" Glulam

Design Property	STANDARD DEPTHS (in inches)										
	11	12 3/8	13 3/4	15 1/8	16 1/2	17 7/8	19 1/4	20 5/8	22	23 3/8	
Area (in. ²)	61	68	76	83	91	98	106	113	121	129	
Section Modulus (in. ³)	111	140	173	210	250	293	340	390	444	501	
Moment of Inertia (in. ⁴)	610	869	1191	1586	2059	2618	3269	4021	4880	5854	
Weight (lbs/LF)	16	18	20	22	24	26	28	30	32	34	

6-3/4" Glulam

Design Property	STANDARD DEPTHS (in inches)															
	8 1/4	9 5/8	11	12 3/8	13 3/4	15 1/8	16 1/2	17 7/8	19 1/4	20 5/8	22	23 3/8	24 3/4	26 1/8	27 3/4	28 7/8
Area (in. ²)	56	65	74	84	93	102	111	121	130	139	149	158	167	176	187	195
Section Modulus (in. ³)	77	104	136	172	213	257	306	359	417	479	545	615	689	768	866	938
Moment of Inertia (in. ⁴)	316	502	749	1066	1462	1946	2527	3213	4012	4935	5990	7184	8528	10030	12020	13542
Weight (lbs/LF)	14.7	17.1	19.6	22.0	24.5	26.9	29.4	31.8	34.3	36.7	39.2	41.6	44.1	46.5	49.4	51.4

8-3/4" Glulam

Design Property	STANDARD DEPTHS (in inches)															
	8 1/4	9 5/8	11	12 3/8	13 3/4	15 1/8	16 1/2	17 7/8	19 1/4	20 5/8	22	23 3/8	24 3/4	26 1/8	27 3/4	28 7/8
Area (in. ²)	72	84	96	108	120	132	144	156	168	180	193	205	217	229	243	253
Section Modulus (in. ³)	99	135	176	223	276	334	397	466	540	620	706	797	893	995	1123	1216
Moment of Inertia (in. ⁴)	409	650	971	1382	1896	2523	3276	4165	5201	6397	7764	9313	11055	13002	15582	17555
Weight (lbs/LF)	19.0	22.2	25.4	28.6	31.7	34.9	38.1	41.3	44.4	47.6	50.8	54.0	57.1	60.3	64.1	66.7

Window, Door and Garage Door Headers

Key - Each cell contains two nominal header sizes:

- Row 1: Header size for bearing length = 3.0"
- Row 2: Header size for bearing length = 1-1/2"

Steps in Using This Table:

1. Find the row with the appropriate roof loading conditions (Live Load, Dead Load & LDF).
2. Find the clear opening that meets or exceeds the window, door, or garage door size.
3. Find the span of the trusses or rafters that frame into the header.
4. Select the proper header size.

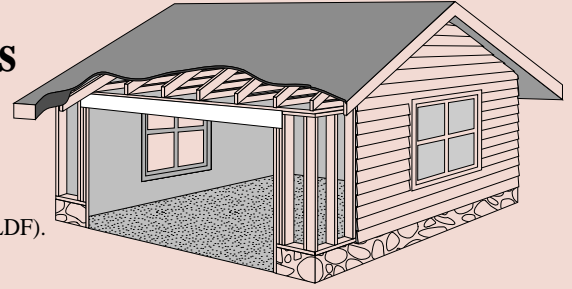

Glulam Selection Table for Window, Door and Garage Door Headers

Roof Loading	Clear Opening	Span of Supported Roof Framing						
		16'	20'	24'	28'	32'	36'	40'
Live 25 PSF Dead 15 PSF LDF 1.15	4'	3-1/8 x 8-1/4	3-1/8 x 8-1/4	3-1/8 x 8-1/4	3-1/8 x 8-1/4	3-1/8 x 8-1/4	3-1/8 x 8-1/4	3-1/8 x 8-1/4
	6'	3-1/8 x 8-1/4	3-1/8 x 8-1/4	3-1/8 x 8-1/4	3-1/8 x 8-1/4	3-1/8 x 8-1/4	3-1/8 x 8-1/4	3-1/8 x 8-1/4
		3-1/8 x 8-1/4	3-1/8 x 8-1/4	3-1/8 x 8-1/4	3-1/8 x 8-1/4	3-1/8 x 8-1/4	3-1/8 x 8-1/4	3-1/8 x 8-1/4
	8'	3-1/8 x 8-1/4	3-1/8 x 8-1/4	3-1/8 x 8-1/4	3-1/8 x 8-1/4	3-1/8 x 8-1/4	3-1/8 x 8-1/4	3-1/8 x 8-1/4
		3-1/8 x 8-1/4	3-1/8 x 8-1/4	3-1/8 x 8-1/4	3-1/8 x 8-1/4	3-1/8 x 8-1/4	3-1/8 x 8-1/4	5-1/8 x 8-1/4
	9'	3-1/8 x 8-1/4	3-1/8 x 8-1/4	3-1/8 x 8-1/4	3-1/8 x 8-1/4	3-1/8 x 8-1/4	3-1/8 x 8-1/4	3-1/8 x 9-5/8
		3-1/8 x 8-1/4	3-1/8 x 8-1/4	3-1/8 x 8-1/4	3-1/8 x 8-1/4	3-1/8 x 8-1/4	3-1/8 x 8-1/4	5-1/8 x 8-1/4
	10'	3-1/8 x 8-1/4	3-1/8 x 8-1/4	3-1/8 x 8-1/4	3-1/8 x 8-1/4	3-1/8 x 9-5/8	3-1/8 x 9-5/8	3-1/8 x 9-5/8
		3-1/8 x 8-1/4	3-1/8 x 8-1/4	3-1/8 x 8-1/4	3-1/8 x 8-1/4	3-1/8 x 9-5/8	5-1/8 x 8-1/4	5-1/8 x 8-1/4
	12'	3-1/8 x 8-1/4	3-1/8 x 9-5/8	3-1/8 x 9-5/8	3-1/8 x 11	3-1/8 x 11	3-1/8 x 12-3/8	3-1/8 x 12-3/8
		3-1/8 x 8-1/4	3-1/8 x 8-1/4	3-1/8 x 8-1/4	3-1/8 x 9-5/8	3-1/8 x 9-5/8	3-1/8 x 9-5/8	3-1/8 x 9-5/8
	16'	3-1/8 x 8-1/4	5-1/8 x 8-1/4	5-1/8 x 8-1/4	5-1/8 x 8-1/4	5-1/8 x 8-1/4	5-1/8 x 8-1/4	5-1/8 x 8-1/4
3-1/8 x 8-1/4		3-1/8 x 9-5/8	3-1/8 x 9-5/8	3-1/8 x 9-5/8	3-1/8 x 11	3-1/8 x 11	3-1/8 x 11	
18'	5-1/8 x 8-1/4	5-1/8 x 8-1/4	5-1/8 x 8-1/4	5-1/8 x 8-1/4	5-1/8 x 8-1/4	5-1/8 x 8-1/4	6-3/4 x 8-1/4	
	3-1/8 x 9-5/8	3-1/8 x 11	3-1/8 x 11	3-1/8 x 11	3-1/8 x 11	3-1/8 x 11	3-1/8 x 12-3/8	
Live 30 PSF Dead 15 PSF LDF 1.15	4'	5-1/8 x 8-1/4	5-1/8 x 8-1/4	5-1/8 x 8-1/4	5-1/8 x 8-1/4	6-3/4 x 8-1/4	6-3/4 x 8-1/4	
	6'	3-1/8 x 11	3-1/8 x 11	3-1/8 x 12-3/8	3-1/8 x 12-3/8	3-1/8 x 12-3/8	5-1/8 x 9-5/8	
		5-1/8 x 8-1/4	5-1/8 x 9-5/8	6-3/4 x 8-1/4	6-3/4 x 8-1/4	6-3/4 x 9-5/8	6-3/4 x 9-5/8	3-1/8 x 8-1/4
	8'	3-1/8 x 11	3-1/8 x 12-3/8	3-1/8 x 12-3/8	3-1/8 x 13-3/4	5-1/8 x 11	5-1/8 x 11	5-1/8 x 12-3/8
		5-1/8 x 9-5/8	6-3/4 x 9-5/8	6-3/4 x 9-5/8	6-3/4 x 9-5/8	6-3/4 x 9-5/8	6-3/4 x 9-5/8	3-1/8 x 8-1/4
	9'	3-1/8 x 12-3/8	3-1/8 x 13-3/4	3-1/8 x 13-3/4	5-1/8 x 11	5-1/8 x 11	5-1/8 x 12-3/8	5-1/8 x 12-3/8
		5-1/8 x 9-5/8	6-3/4 x 9-5/8	6-3/4 x 9-5/8	6-3/4 x 9-5/8	3-1/8 x 9-5/8	3-1/8 x 9-5/8	3-1/8 x 9-5/8
	10'	3-1/8 x 12-3/8	3-1/8 x 13-3/4	5-1/8 x 12-3/8	5-1/8 x 12-3/8	5-1/8 x 12-3/8	5-1/8 x 12-3/8	5-1/8 x 13-3/4
		5-1/8 x 11	6-3/4 x 11	6-3/4 x 11	3-1/8 x 9-5/8	3-1/8 x 9-5/8	3-1/8 x 11	3-1/8 x 11
	12'	3-1/8 x 13-3/4	5-1/8 x 12-3/8	5-1/8 x 12-3/8	5-1/8 x 12-3/8	5-1/8 x 13-3/4	5-1/8 x 13-3/4	5-1/8 x 15-1/8
		6-3/4 x 11	6-3/4 x 11	3-1/8 x 11	3-1/8 x 11	3-1/8 x 12-3/8	3-1/8 x 12-3/8	3-1/8 x 13-3/4
	16'	3-1/8 x 15-1/8	5-1/8 x 12-3/8	5-1/8 x 13-3/4	5-1/8 x 13-3/4	5-1/8 x 13-3/4	5-1/8 x 15-1/8	6-3/4 x 13-3/4
6-3/4 x 11		3-1/8 x 12-3/8	3-1/8 x 13-3/4	3-1/8 x 15-1/8	3-1/8 x 15-1/8	5-1/8 x 12-3/8	5-1/8 x 13-3/4	
18'	3-1/8 x 15-1/8	5-1/8 x 13-3/4	5-1/8 x 13-3/4	5-1/8 x 15-1/8	5-1/8 x 15-1/8	5-1/8 x 15-1/8	6-3/4 x 13-3/4	
	6-3/4 x 12-3/8	3-1/8 x 13-3/4	3-1/8 x 15-1/8	3-1/8 x 16-1/2	5-1/8 x 13-3/4	5-1/8 x 15-1/8	5-1/8 x 15-1/8	
Live 40 PSF Dead 15 PSF LDF 1.15	4'	5-1/8 x 13-3/4	5-1/8 x 15-1/8	5-1/8 x 15-1/8	5-1/8 x 15-1/8	6-3/4 x 13-3/4	6-3/4 x 15-1/8	
	6'	3-1/8 x 8-1/4	3-1/8 x 8-1/4	3-1/8 x 8-1/4	3-1/8 x 8-1/4	3-1/8 x 8-1/4	3-1/8 x 8-1/4	
		5-1/8 x 13-3/4	5-1/8 x 15-1/8	5-1/8 x 16-1/2	6-3/4 x 15-1/8	6-3/4 x 15-1/8	6-3/4 x 15-1/8	3-1/8 x 8-1/4
	8'	3-1/8 x 8-1/4	3-1/8 x 8-1/4	3-1/8 x 8-1/4	3-1/8 x 8-1/4	3-1/8 x 8-1/4	3-1/8 x 8-1/4	3-1/8 x 8-1/4
		3-1/8 x 8-1/4	3-1/8 x 8-1/4	3-1/8 x 8-1/4	3-1/8 x 8-1/4	3-1/8 x 9-5/8	3-1/8 x 9-5/8	3-1/8 x 9-5/8
	9'	3-1/8 x 8-1/4	3-1/8 x 8-1/4	3-1/8 x 8-1/4	5-1/8 x 8-1/4	5-1/8 x 8-1/4	5-1/8 x 8-1/4	5-1/8 x 8-1/4
		3-1/8 x 8-1/4	3-1/8 x 8-1/4	3-1/8 x 9-5/8	3-1/8 x 9-5/8	3-1/8 x 9-5/8	3-1/8 x 11	3-1/8 x 11
	10'	3-1/8 x 8-1/4	3-1/8 x 8-1/4	5-1/8 x 8-1/4	5-1/8 x 8-1/4	5-1/8 x 8-1/4	5-1/8 x 8-1/4	5-1/8 x 8-1/4
		3-1/8 x 8-1/4	3-1/8 x 9-5/8	3-1/8 x 9-5/8	3-1/8 x 11	3-1/8 x 11	3-1/8 x 11	3-1/8 x 12-3/8
	12'	3-1/8 x 8-1/4	3-1/8 x 9-5/8	5-1/8 x 8-1/4	5-1/8 x 8-1/4	5-1/8 x 8-1/4	5-1/8 x 8-1/4	5-1/8 x 8-1/4
		3-1/8 x 9-5/8	3-1/8 x 11	3-1/8 x 11	3-1/8 x 12-3/8	3-1/8 x 13-3/4	3-1/8 x 13-3/4	5-1/8 x 11
	16'	3-1/8 x 9-5/8	5-1/8 x 8-1/4	5-1/8 x 9-5/8	5-1/8 x 9-5/8	6-3/4 x 9-5/8	6-3/4 x 9-5/8	6-3/4 x 9-5/8
3-1/8 x 12-3/8		3-1/8 x 13-3/4	3-1/8 x 15-1/8	5-1/8 x 12-3/8	5-1/8 x 13-3/4	5-1/8 x 13-3/4	5-1/8 x 15-1/8	
18'	5-1/8 x 11	5-1/8 x 11	6-3/4 x 11	6-3/4 x 11				
	3-1/8 x 15-1/8	3-1/8 x 16-1/2	5-1/8 x 13-3/4	5-1/8 x 13-3/4	5-1/8 x 15-1/8	5-1/8 x 16-1/2	5-1/8 x 16-1/2	
		5-1/8 x 12-3/8	6-3/4 x 11	6-3/4 x 12-3/8				

Continued on next page

Glulam Selection Table for Window, Door and Garage Door Headers, continued

Roof Loading	Clear Opening	Span of Supported Roof Framing							
		16'	20'	24'	28'	32'	36'	40'	
Live 20 PSF Dead 15 PSF LDF 1.25	4'	3-1/8 x 8-1/4	3-1/8 x 8-1/4	3-1/8 x 8-1/4	3-1/8 x 8-1/4	3-1/8 x 8-1/4	3-1/8 x 8-1/4	3-1/8 x 8-1/4	
		3-1/8 x 8-1/4	3-1/8 x 8-1/4	3-1/8 x 8-1/4	3-1/8 x 8-1/4	3-1/8 x 8-1/4	3-1/8 x 8-1/4	3-1/8 x 8-1/4	
	6'	3-1/8 x 8-1/4	3-1/8 x 8-1/4	3-1/8 x 8-1/4	3-1/8 x 8-1/4	3-1/8 x 8-1/4	3-1/8 x 8-1/4	3-1/8 x 8-1/4	
		3-1/8 x 8-1/4	3-1/8 x 8-1/4	3-1/8 x 8-1/4	3-1/8 x 8-1/4	3-1/8 x 8-1/4	3-1/8 x 8-1/4	3-1/8 x 8-1/4	
	8'	3-1/8 x 8-1/4	3-1/8 x 8-1/4	3-1/8 x 8-1/4	3-1/8 x 8-1/4	3-1/8 x 8-1/4	3-1/8 x 8-1/4	3-1/8 x 8-1/4	
		3-1/8 x 8-1/4	3-1/8 x 8-1/4	3-1/8 x 8-1/4	3-1/8 x 8-1/4	3-1/8 x 8-1/4	3-1/8 x 8-1/4	3-1/8 x 8-1/4	
	9'	3-1/8 x 8-1/4	3-1/8 x 8-1/4	3-1/8 x 8-1/4	3-1/8 x 8-1/4	3-1/8 x 8-1/4	3-1/8 x 8-1/4	3-1/8 x 8-1/4	
		3-1/8 x 8-1/4	3-1/8 x 8-1/4	3-1/8 x 8-1/4	3-1/8 x 8-1/4	3-1/8 x 8-1/4	3-1/8 x 8-1/4	5-1/8 x 8-1/4	
	10'	3-1/8 x 8-1/4	3-1/8 x 8-1/4	3-1/8 x 8-1/4	3-1/8 x 8-1/4	3-1/8 x 8-1/4	3-1/8 x 9-5/8	3-1/8 x 9-5/8	
		3-1/8 x 8-1/4	3-1/8 x 8-1/4	3-1/8 x 8-1/4	3-1/8 x 8-1/4	3-1/8 x 8-1/4	5-1/8 x 8-1/4	5-1/8 x 8-1/4	
	12'	3-1/8 x 8-1/4	3-1/8 x 8-1/4	3-1/8 x 9-5/8	3-1/8 x 9-5/8	3-1/8 x 9-5/8	3-1/8 x 11	3-1/8 x 11	
		3-1/8 x 8-1/4	3-1/8 x 8-1/4	3-1/8 x 9-5/8	3-1/8 x 9-5/8	5-1/8 x 8-1/4	5-1/8 x 8-1/4	5-1/8 x 9-5/8	
	16'	3-1/8 x 11	3-1/8 x 11	3-1/8 x 12-3/8	3-1/8 x 12-3/8	3-1/8 x 13-3/4	3-1/8 x 13-3/4	3-1/8 x 15-1/8	
		3-1/8 x 11	3-1/8 x 11	5-1/8 x 11	5-1/8 x 11	5-1/8 x 11	5-1/8 x 11	6-3/4 x 11	
	18'	3-1/8 x 12-3/8	3-1/8 x 12-3/8	3-1/8 x 13-3/4	3-1/8 x 13-3/4	3-1/8 x 15-1/8	3-1/8 x 15-1/8	5-1/8 x 13-3/4	
		3-1/8 x 12-3/8	5-1/8 x 11	5-1/8 x 11	5-1/8 x 12-3/8	6-3/4 x 11	6-3/4 x 12-3/8	6-3/4 x 12-3/8	
	Live 20 PSF Dead 20 PSF LDF 1.25	4'	3-1/8 x 8-1/4	3-1/8 x 8-1/4	3-1/8 x 8-1/4	3-1/8 x 8-1/4	3-1/8 x 8-1/4	3-1/8 x 8-1/4	3-1/8 x 8-1/4
			3-1/8 x 8-1/4	3-1/8 x 8-1/4	3-1/8 x 8-1/4	3-1/8 x 8-1/4	3-1/8 x 8-1/4	3-1/8 x 8-1/4	3-1/8 x 8-1/4
6'		3-1/8 x 8-1/4	3-1/8 x 8-1/4	3-1/8 x 8-1/4	3-1/8 x 8-1/4	3-1/8 x 8-1/4	3-1/8 x 8-1/4	3-1/8 x 8-1/4	
		3-1/8 x 8-1/4	3-1/8 x 8-1/4	3-1/8 x 8-1/4	3-1/8 x 8-1/4	3-1/8 x 8-1/4	3-1/8 x 8-1/4	3-1/8 x 8-1/4	
8'		3-1/8 x 8-1/4	3-1/8 x 8-1/4	3-1/8 x 8-1/4	3-1/8 x 8-1/4	3-1/8 x 8-1/4	3-1/8 x 8-1/4	3-1/8 x 8-1/4	
		3-1/8 x 8-1/4	3-1/8 x 8-1/4	3-1/8 x 8-1/4	3-1/8 x 8-1/4	3-1/8 x 8-1/4	3-1/8 x 8-1/4	5-1/8 x 8-1/4	
9'		3-1/8 x 8-1/4	3-1/8 x 8-1/4	3-1/8 x 8-1/4	3-1/8 x 8-1/4	3-1/8 x 8-1/4	3-1/8 x 8-1/4	3-1/8 x 9-5/8	
		3-1/8 x 8-1/4	3-1/8 x 8-1/4	3-1/8 x 8-1/4	3-1/8 x 8-1/4	3-1/8 x 8-1/4	5-1/8 x 8-1/4	5-1/8 x 8-1/4	
10'		3-1/8 x 8-1/4	3-1/8 x 8-1/4	3-1/8 x 8-1/4	3-1/8 x 8-1/4	3-1/8 x 9-5/8	3-1/8 x 9-5/8	3-1/8 x 9-5/8	
		3-1/8 x 8-1/4	3-1/8 x 8-1/4	3-1/8 x 8-1/4	3-1/8 x 8-1/4	5-1/8 x 8-1/4	5-1/8 x 8-1/4	5-1/8 x 8-1/4	
12'		3-1/8 x 8-1/4	3-1/8 x 9-5/8	3-1/8 x 9-5/8	3-1/8 x 9-5/8	3-1/8 x 11	3-1/8 x 11	3-1/8 x 12-3/8	
		3-1/8 x 8-1/4	3-1/8 x 9-5/8	3-1/8 x 9-5/8	5-1/8 x 8-1/4	5-1/8 x 9-5/8	5-1/8 x 9-5/8	5-1/8 x 9-5/8	
16'		3-1/8 x 11	3-1/8 x 12-3/8	3-1/8 x 12-3/8	3-1/8 x 13-3/4	3-1/8 x 13-3/4	3-1/8 x 15-1/8	5-1/8 x 12-3/8	
		3-1/8 x 11	5-1/8 x 9-5/8	5-1/8 x 11	5-1/8 x 11	6-3/4 x 11	6-3/4 x 11	6-3/4 x 11	
18'		3-1/8 x 12-3/8	3-1/8 x 13-3/4	3-1/8 x 13-3/4	3-1/8 x 15-1/8	3-1/8 x 16-1/2	5-1/8 x 13-3/4	5-1/8 x 13-3/4	
		5-1/8 x 11	5-1/8 x 11	5-1/8 x 12-3/8	6-3/4 x 11	6-3/4 x 12-3/8	6-3/4 x 12-3/8	7 x 11-1/4	

Notes:

1. This table is for headers carrying roof loads only. For all other load conditions use the PLF tables.
2. Deflection is limited to L/240 for Live Load and L/180 for Total Load.
3. Design span is assumed to be the clear opening plus the bearing length of 1-1/2" (1 trimmer) or 3.0" (2 trimmers).
4. For bearing lengths longer than 3.0", use the Allowable Roof Load Tables to get required header size. Use of longer bearing lengths may allow the use of a smaller Glulam.
5. The header size is based on the load carried by 1/2 the span of the roof framing plus a 24" overhang.
6. It is assumed that the header has the truss or rafter framing attached to its top, and is supported laterally at the bearing points.
7. Live load reductions may be taken per BOCA, UBC and SBC. Live Load reductions have not been taken to produce the table above.
8. For loads other than those shown, see Roof PLF Table, or use a load condition that applies a higher load than you have.
9. Beam weight is included in all tables and does not have to be added to the applied load.
10. Blank spaces require more than a 1-1/2" bearing.
11. Beams and headers are assumed to be used under dry conditions and normal temperatures.
12. This table assumes a uniform load condition. Any concentrated load applications must be analyzed separately or converted to an equivalent uniform load.
13. Dead and live loads used to select a beam or header should be equal to or greater than the actual loads applied.

Window, Door, and Garage Door Header Example Problem

Load Conditions:	Live = 30 psf Dead = 15 psf LDF = 1.15
Clear Opening:	12'
Span of Supported Roof Framing:	32'
Anthony 24F Glulam Selected:	3-1/8 x 12-3/8 w/2 trimmers 5-1/8 x 9-5/8 w/1 trimmer

Load Duration Factor (LDF)	
LDF	Duration
1.00	10 years; normal loads
1.15	2 month; snow load
1.25	7 days; non-snow or construction

Allowable Roof Load Tables LDF=1.15

3-1/8" & 5-1/8" Widths - Standard Depths

Key - for each clear span there are three numbers:

- Row 1: Maximum Total Load with LDF of 1.15, and deflection limited to L/180
- Row 2: Maximum Live Load limited by deflection of L/240
- Row 3: Required Bearing Length in trimmer thickness (e.g., 1.5 = 1 trimmer, 3.0 = 2 trimmers, etc.)

These tables can be used to size simple span beams and headers that carry uniform loads. The PLF loads must be calculated and take into account all floor and roof framing loads coming onto the beam or header.

Allowable Loads for Anthony Glulam in Pounds per Linear Foot

Actual Span	3 1/8"							5 1/8"										
	Depth (in.)							Depth (in.)										
	8 1/4	9 5/8	11	12 3/8	13 3/4	15 1/8	16 1/2	17 7/8	11	12 3/8	13 3/4	15 1/8	16 1/2	17 7/8	19 1/4	20 5/8	22	23 3/8
6'	1805	2458	3212	4056	4785	5612	6554	7640	5267	6651	7848	9203	10749	12530	14604	17049	19975	23538
	1805	2458	3212	4056	4785	5612	6554	7640	5267	6651	7848	9203	10749	12530	14604	17049	19975	23538
	3	4.5	4.5	6	7.5	9	10.5	12	4.5	6	7.5	9	10.5	12	13.5	16.5	19.5	24
7'	1324	1804	2357	2985	3686	4356	5009	5736	3866	4895	6045	7144	8214	9408	10745	12255	13973	15945
	1324	1804	2357	2985	3686	4356	5009	5736	3866	4895	6045	7144	8214	9408	10745	12255	13973	15945
	3	3	4.5	6	6	7.5	9	10.5	4.5	6	6	7.5	9	10.5	12	13.5	15	18
8'	1012	1379	1803	2283	2819	3413	4052	4591	2956	3744	4624	5597	6645	7529	8497	9563	10741	12052
	1012	1379	1803	2283	2819	3413	4052	4591	2956	3744	4624	5597	6645	7529	8497	9563	10741	12052
	3	3	4.5	4.5	6	7.5	9	9	4.5	4.5	6	7.5	9	9	10.5	12	13.5	15
9'	798	1088	1422	1801	2225	2694	3207	3765	2333	2954	3649	4418	5260	6175	7025	7839	8722	9684
	798	1088	1422	1801	2225	2694	3207	3765	2333	2954	3649	4418	5260	6175	7025	7839	8722	9684
	3	3	3	4.5	6	6	7.5	9	3	4.5	6	6	7.5	9	9	10.5	12	13.5
10'	645	880	1150	1457	1800	2180	2595	3047	1886	2390	2952	3574	4256	4997	5797	6640	7340	8092
	585	880	1150	1457	1800	2180	2595	3047	1886	2390	2952	3574	4256	4997	5797	6640	7340	8092
	1.5	3	3	4.5	4.5	6	6	7.5	3	4.5	4.5	6	6	7.5	9	10.5	10.5	12
11'	532	726	949	1202	1486	1799	2142	2515	1556	1972	2437	2950	3513	4125	4787	5497	6256	6949
	439	698	949	1202	1486	1799	2142	2515	1556	1972	2437	2950	3513	4125	4787	5497	6256	6949
	1.5	3	3	3	4.5	4.5	6	7.5	3	3	4.5	4.5	6	7.5	7.5	9	10.5	12
12'	444	608	796	1009	1247	1510	1798	2111	1305	1654	2044	2476	2949	3462	4018	4614	5240	5899
	338	538	796	1009	1247	1510	1798	2111	1305	1654	2044	2476	2949	3462	4018	4614	5240	5899
	1.5	3	3	3	4.5	4.5	6	6	3	3	4.5	4.5	6	6	7.5	9	9	10.5
13'	348	517	677	858	1060	1284	1530	1797	1110	1407	1739	2106	2509	2947	3419	3915	4442	5002
	266	423	631	858	1060	1284	1530	1797	1035	1407	1739	2106	2509	2947	3419	3915	4442	5002
	1.5	1.5	3	3	4.5	4.5	6	6	3	3	4.5	4.5	6	6	7.5	7.5	9	10.5
14'	277	443	582	738	913	1106	1317	1547	955	1211	1497	1813	2160	2537	2935	3359	3812	4292
	213	338	505	719	913	1106	1317	1547	829	1180	1497	1813	2160	2537	2935	3359	3812	4292
	1.5	1.5	3	3	3	4.5	4.5	6	3	3	3	4.5	4.5	6	6	7.5	7.5	9
15'	224	359	506	642	794	962	1146	1346	830	1053	1302	1577	1879	2200	2544	2912	3305	3722
	173	275	411	585	794	962	1146	1346	674	959	1302	1577	1879	2200	2544	2912	3305	3722
	1.5	1.5	3	3	3	4.5	4.5	4.5	3	3	3	4.5	4.5	4.5	6	6	7.5	9
16'	183	294	442	563	696	844	1005	1181	725	923	1142	1383	1645	1924	2226	2548	2892	3256
	143	227	338	482	661	844	1005	1181	555	790	1084	1383	1645	1924	2226	2548	2892	3256
	1.5	1.5	3	3	3	4.5	4.5	4.5	3	3	3	4.5	4.5	6	6	7.5	7.5	9
17'	152	244	367	497	615	746	889	1044	602	816	1009	1222	1450	1697	1962	2247	2550	2872
	119	189	282	402	551	734	889	1044	463	659	904	1203	1450	1697	1962	2247	2550	2872
	1.5	1.5	1.5	3	3	4.5	4.5	4.5	1.5	3	3	3	4.5	4.5	6	6	7.5	7.5
18'	127	204	308	441	548	664	791	930	505	723	898	1084	1287	1506	1742	1995	2265	2551
	100	159	238	338	464	618	791	930	390	555	761	1014	1287	1506	1742	1995	2265	2551
	1.5	1.5	1.5	3	3	3	4.5	4.5	1.5	3	3	3	4.5	4.5	6	6	7.5	7.5
19'	107	172	260	373	490	594	709	833	427	612	803	968	1150	1346	1557	1783	2024	2280
	85	135	202	288	395	525	682	833	332	472	647	862	1119	1346	1557	1783	2024	2280
	1.5	1.5	1.5	3	3	3	4.5	4.5	1.5	3	3	3	3	4.5	4.5	6	6	6
20'	91	147	222	319	440	535	638	750	364	522	721	870	1032	1209	1399	1602	1819	2049
	73	116	173	247	338	451	585	744	284	405	555	739	959	1209	1399	1602	1819	2049
	1.5	1.5	1.5	1.5	3	3	3	4.5	1.5	1.5	3	3	3	4.5	4.5	4.5	6	6
21'	77	126	190	274	378	484	578	679	312	449	620	785	932	1091	1263	1447	1643	1851
	63	100	150	213	292	389	505	642	246	350	480	638	829	1054	1263	1447	1643	1851
	1.5	1.5	1.5	1.5	3	3	3	4.5	1.5	1.5	3	3	3	4.5	4.5	4.5	6	6
22'	66	108	164	237	327	439	525	618	269	388	537	712	845	990	1146	1313	1491	1680
	55	87	130	185	254	338	439	559	214	304	417	555	721	916	1144	1313	1491	1680
	1.5	1.5	1.5	1.5	3	3	3	3	1.5	1.5	3	3	3	3	4.5	4.5	4.5	6
23'	57	94	143	206	285	382	479	564	234	338	468	627	770	902	1044	1196	1358	1531
	48	76	114	162	223	296	385	489	187	266	365	486	631	802	1002	1196	1358	1531
	1.5	1.5	1.5	1.5	1.5	3	3	3	1.5	1.5	1.5	3	3	3	4.5	4.5	4.5	6
24'	49	81	124	180	250	335	437	515	204	295	409	549	703	824	954	1094	1242	1400
	42	67	100	143	196	261	338	430	164	234	321	428	555	706	882	1084	1242	1400
	1.5	1.5	1.5	1.5	1.5	3	3	3	1.5	1.5	1.5	3	3	3	4.5	4.5	4.5	4.5
25'	43	71	109	158	219	295	385	473	179	259	360	483	632	756	875	1003	1140	1285
	37	59	89	126	173	231	299	381	146	207	284	378	491	624	780	959	1140	1285
	1.5	1.5	1.5	1.5	1.5	3	3	3	1.5	1.5	1.5	3	3	3	3	4.5	4.5	4.5
26'	37	62	96	139	194	261	341	435	157	228	318	427	559	696	806	924	1050	1183
	33	53	79	112	154	205	266	338	129	184	253	336	437	555	693	853	1035	1183
	1.5	1.5	1.5	1.5	1.5	1.5	3	3	1.5	1.5	1.5	1.5	3	3	3	4.5	4.5	4.5
27'	33	55	85	123	172	231	303	388	139	202	282	379	497	636	744	853	969	1093
	30	47	70	100	138	183	238	302	116	164	226	300	390	496	619	761	924	1093
	1.5	1.5	1.5	1.5	1.5	1.5	3	3	1.5	1.5	1.5	1.5	3	3	3	4.5	4.5	4.5
28'	29	48	75	109	153	206	270	346	123	179	251	338	443	568	688	790	897	1012
	27	42	63	90	123	164	213	271	104	147	202	269	350	444	555	683	829	994
	1.5	1.5	1.5	1.5	1.5	1.5	3	3	1.5	1.5	1.5	1.5	3	3	3	3	4.5	4.5
29'	25	43	66	97	136	184	242	310	109	160	224	302	397	509	639	733	833	939
	24	38	57	81	111	148	192	244	93	133	182	242	315	400	500	615	746	895
	1.5	1.5	1.5	1.5	1.5	1.5	3	3	1.5	1.5	1.5	1.5	3	3	3	3	4.5	4.5
30'	22	38	59	87	122	165	217	279	97	143	200	271	356	457	575	682	775	874
	22	34	51	73	100	133	173	220	84	120	164	219	284	361	451</			

Allowable Roof Load Tables LDF=1.25

3-1/8" & 5-1/8" Widths - Standard Depths

Key - for each clear span there are three numbers:

- Row 1: Maximum Total Load with LDF of 1.25, and deflection limited to L/180
- Row 2: Maximum Live Load limited by deflection of L/240
- Row 3: Required Bearing Length in trimmer thickness (e.g., 1.5 = 1 trimmer, 3.0 = 2 trimmers, etc.)

These tables can be used to size simple span beams and headers that carry uniform loads. The PLF loads must be calculated and take into account all floor and roof framing loads coming onto the beam or header.

Allowable Loads for Anthony Glulam in Pounds per Linear Foot

Actual Span	3 1/8"							5 1/8"										
	Depth (in.)							Depth (in.)										
	8 1/4	9 5/8	11	12 3/8	13 3/4	15 1/8	16 1/2	17 7/8	11	12 3/8	13 3/4	15 1/8	16 1/2	17 7/8	19 1/4	20 5/8	22	23 3/8
6'	1962	2672	3492	4409	5203	6101	7125	8306	5727	7231	8532	10005	11686	13622	15876	18534	21714	25587
	1962	2672	3492	4409	5203	6101	7125	8306	5727	7231	8532	10005	11686	13622	15876	18534	21714	25587
	3	4.5	6	7.5	7.5	9	10.5	13.5	6	7.5	7.5	9	10.5	13.5	15	18	22.5	27
7'	1440	1961	2563	3245	4008	4736	5446	6236	4203	5322	6572	7767	8931	10228	11682	13323	15191	17334
	1440	1961	2563	3245	4008	4736	5446	6236	4203	5322	6572	7767	8931	10228	11682	13323	15191	17334
	3	4.5	4.5	6	7.5	9	10.5	12	4.5	6	7.5	9	10.5	12	13.5	15	16.5	19.5
8'	1101	1500	1960	2482	3066	3711	4406	4991	3215	4071	5028	6085	7225	8186	9238	10397	11678	13103
	1101	1500	1960	2482	3066	3711	4406	4991	3215	4071	5028	6085	7225	8186	9238	10397	11678	13103
	3	3	4.5	4.5	6	7.5	9	10.5	4.5	4.5	6	7.5	9	10.5	12	13.5	15	16.5
9'	868	1183	1547	1959	2420	2929	3487	4094	2537	3213	3968	4804	5719	6714	7639	8523	9483	10529
	802	1183	1547	1959	2420	2929	3487	4094	2537	3213	3968	4804	5719	6714	7639	8523	9483	10529
	3	3	4.5	4.5	6	7.5	7.5	9	4.5	4.5	6	7.5	7.5	9	10.5	12	13.5	15
10'	702	957	1251	1585	1958	2370	2822	3313	2052	2599	3211	3887	4628	5434	6304	7220	7981	8799
	585	929	1251	1585	1958	2370	2822	3313	2052	2599	3211	3887	4628	5434	6304	7220	7981	8799
	3	3	3	4.5	4.5	6	7.5	9	3	4.5	4.5	6	7.5	9	9	10.5	12	13.5
11'	579	789	1032	1308	1616	1957	2330	2736	1693	2145	2650	3209	3821	4486	5205	5977	6803	7556
	439	698	1032	1308	1616	1957	2330	2736	1693	2145	2650	3209	3821	4486	5205	5977	6803	7556
	1.5	3	3	4.5	4.5	6	6	7.5	3	4.5	4.5	6	6	7.5	9	10.5	12	12
12'	444	662	866	1097	1356	1642	1955	2296	1420	1800	2224	2693	3207	3766	4369	5018	5698	6415
	338	538	802	1097	1356	1642	1955	2296	1316	1800	2224	2693	3207	3766	4369	5018	5698	6415
	1.5	3	3	3	4.5	4.5	6	7.5	3	3	4.5	4.5	6	7.5	7.5	9	10.5	12
13'	348	556	736	933	1154	1397	1664	1954	1208	1531	1892	2291	2729	3205	3719	4258	4831	5439
	266	423	631	899	1154	1397	1664	1954	1035	1474	1892	2291	2729	3205	3719	4258	4831	5439
	1.5	3	3	3	4.5	4.5	6	6	3	3	4.5	4.5	6	6	7.5	9	9	10.5
14'	277	443	634	803	993	1203	1433	1683	1039	1318	1629	1973	2350	2760	3192	3654	4146	4668
	213	338	505	719	987	1203	1433	1683	829	1180	1618	1973	2350	2760	3192	3654	4146	4668
	1.5	1.5	3	3	4.5	4.5	4.5	6	3	3	4.5	4.5	4.5	6	7.5	7.5	9	10.5
15'	224	359	538	699	864	1046	1246	1464	883	1146	1416	1716	2044	2394	2768	3168	3595	4048
	173	275	411	585	802	1046	1246	1464	674	959	1316	1716	2044	2394	2768	3168	3595	4048
	1.5	1.5	3	3	3	4.5	4.5	6	3	3	3	4.5	4.5	6	6	7.5	7.5	9
16'	183	294	442	613	758	918	1094	1285	725	1005	1243	1506	1790	2094	2421	2772	3146	3542
	143	227	338	482	661	880	1094	1285	555	790	1084	1443	1790	2094	2421	2772	3146	3542
	1.5	1.5	3	3	3	4.5	4.5	6	3	3	3	4.5	4.5	6	6	7.5	7.5	9
17'	152	244	367	525	670	812	967	1137	602	861	1098	1330	1578	1846	2135	2445	2775	3125
	119	189	282	402	551	734	952	1137	463	659	904	1203	1562	1846	2135	2445	2775	3125
	1.5	1.5	1.5	3	3	4.5	4.5	4.5	1.5	3	3	4.5	4.5	6	6	7.5	7.5	7.5
18'	127	204	308	441	596	723	861	1012	505	723	978	1181	1401	1639	1896	2171	2464	2776
	100	159	238	338	464	618	802	1012	390	555	761	1014	1316	1639	1896	2171	2464	2776
	1.5	1.5	1.5	3	3	3	4.5	4.5	1.5	3	3	3	4.5	4.5	6	6	7.5	7.5
19'	107	172	260	373	515	647	772	907	427	612	844	1054	1251	1465	1695	1940	2203	2481
	85	135	202	288	395	525	682	867	332	472	647	862	1119	1422	1695	1940	2203	2481
	1.5	1.5	1.5	3	3	3	4.5	4.5	1.5	3	3	3	4.5	4.5	6	6	7.5	7.5
20'	91	147	222	319	440	583	695	817	364	522	721	947	1124	1316	1523	1744	1980	2230
	73	116	173	247	338	451	585	744	284	405	555	739	959	1220	1523	1744	1980	2230
	1.5	1.5	1.5	1.5	3	3	4.5	4.5	1.5	1.5	3	3	4.5	4.5	6	6	7.5	7.5
21'	77	126	190	274	378	506	629	740	312	449	620	830	1015	1189	1375	1575	1788	2015
	63	100	150	213	292	389	505	642	246	350	480	638	829	1054	1316	1575	1788	2015
	1.5	1.5	1.5	1.5	3	3	3	4.5	1.5	1.5	3	3	3	4.5	4.5	6	6	6
22'	66	108	164	237	327	439	572	673	269	388	537	719	921	1078	1248	1429	1623	1829
	55	87	130	185	254	338	439	559	214	304	417	555	721	916	1144	1408	1623	1829
	1.5	1.5	1.5	1.5	3	3	3	4.5	1.5	1.5	3	3	3	4.5	4.5	6	6	6
23'	57	94	143	206	285	382	499	614	234	338	468	627	818	982	1137	1302	1479	1666
	48	76	114	162	223	296	385	489	187	266	365	486	631	802	1002	1232	1479	1666
	1.5	1.5	1.5	1.5	1.5	3	3	4.5	1.5	1.5	1.5	3	3	4.5	4.5	6	6	6
24'	49	81	124	180	250	335	437	559	204	295	409	549	717	898	1040	1191	1353	1525
	42	67	100	143	196	261	338	430	164	234	321	428	555	706	882	1084	1316	1525
	1.5	1.5	1.5	1.5	1.5	3	3	3	1.5	1.5	1.5	3	3	3	4.5	4.5	4.5	6
25'	43	71	109	158	219	295	385	493	179	259	360	483	632	808	954	1093	1242	1400
	37	59	89	126	173	231	299	381	146	207	284	378	491	624	780	959	1164	1396
	1.5	1.5	1.5	1.5	1.5	3	3	3	1.5	1.5	1.5	3	3	3	4.5	4.5	4.5	6
26'	37	62	96	139	194	261	341	436	157	228	318	427	559	715	878	1007	1143	1289
	33	53	79	112	154	205	266	338	129	184	253	336	437	555	693	853	1035	1241
	1.5	1.5	1.5	1.5	1.5	1.5	3	3	1.5	1.5	1.5	1.5	3	3	4.5	4.5	4.5	4.5
27'	33	55	85	123	172	231	303	388	139	202	282	379	497	636	799	929	1056	1191
	30	47	70	100	138	183	238	302	116	164	226	300	390	496	619	761	924	1109
	1.5	1.5	1.5	1.5	1.5	1.5	3	3	1.5	1.5	1.5	1.5	3	3	3	4.5	4.5	4.5
28'	29	48	75	109	153	206	270	346	123	179	251	338	443	568	713	861	978	1103
	27	42	63	90	123	164	213	271	104	147	202	269	350	444	555	683	829	994
	1.5	1.5	1.5	1.5	1.5	1.5	3	3	1.5	1.5	1.5	1.5	3	3	3	4.5	4.5	4.5
29'	25	43	66	97	136	184	242	310	109	160	224	302	397	509	639	791	908	1024
	24	38	57	81	111	148	192	244	93	133	182	242	315	400	500	615	746	895
	1.5	1.5	1.5	1.5	1.5	1.5	3	3	1.5	1.5	1.5	1.5	3	3	3	4.5	4.5	4.5
30'	22	38	59	87	122	165	217	279	97	143	200	271	356	457	575	712	845	953
	22	34	51	73	100	133	173	2										

Allowable Floor Load Tables LDF=1.00

3-1/2" & 5-1/2" Widths - Standard Depths

Key - for each clear span there are three numbers:

- Row 1: Maximum Total Load with LDF of 1.0, and deflection limited to L/240
- Row 2: Maximum Live Load limited by deflection of L/360
- Row 3: Required Bearing Length in trimmer thickness (e.g., 1.5 = 1 trimmer, 3.0 = 2 trimmers, etc.)

These tables can be used to size simple span beams and headers that carry uniform loads. The PLF loads must be calculated and take into account all floor and roof framing loads coming onto the beam or header.

Allowable Loads for Anthony Glulam in Pounds per Linear Foot

Actual Span	3 1/2"							5 1/2"										
	Depth (in.)							Depth (in.)										
	8 1/4	9 5/8	11	12 3/8	13 3/4	15 1/8	16 1/2	17 7/8	11	12 3/8	13 3/4	15 1/8	16 1/2	17 7/8	19 1/4	20 5/8	22	23 3/8
6'	1757	2393	3127	3948	4659	5463	6381	7439	4913	6204	7321	8585	10028	11690	13624	15906	18636	21961
	1757	2393	3127	3948	4659	5463	6381	7439	4913	6204	7321	8585	10028	11690	13624	15906	18636	21961
	3	3	4.5	6	6	7.5	9	10.5	4.5	6	6	7.5	9	10.5	12	15	16.5	21
7'	1289	1755	2294	2905	3588	4240	4876	5585	3605	4565	5639	6663	7662	8776	10024	11432	13035	14875
	1273	1755	2294	2905	3588	4240	4876	5585	3605	4565	5639	6663	7662	8776	10024	11432	13035	14875
	3	3	4.5	4.5	6	7.5	7.5	9	4.5	4.5	6	7.5	7.5	9	10.5	12	13.5	15
8'	985	1342	1754	2222	2744	3322	3944	4469	2757	3491	4312	5220	6198	7023	7926	8920	10020	11242
	853	1342	1754	2222	2744	3322	3944	4469	2757	3491	4312	5220	6198	7023	7926	8920	10020	11242
	3	3	3	4.5	4.5	6	7.5	7.5	3	4.5	4.5	6	7.5	7.5	9	10.5	12	13.5
9'	776	1058	1384	1753	2165	2622	3121	3665	2175	2754	3403	4120	4905	5759	6552	7311	8135	9033
	599	951	1384	1753	2165	2622	3121	3665	2175	2754	3403	4120	4905	5759	6552	7311	8135	9033
	1.5	3	3	4.5	4.5	6	6	7.5	3	4.5	4.5	6	6	7.5	9	9	10.5	12
10'	627	856	1119	1418	1752	2121	2525	2965	1758	2228	2752	3333	3968	4660	5406	6192	6845	7547
	437	694	1035	1418	1752	2121	2525	2965	1627	2228	2752	3333	3968	4660	5406	6192	6845	7547
	1.5	3	3	3	4.5	4.5	6	7.5	3	3	4.5	4.5	6	7.5	7.5	9	10.5	10.5
11'	484	705	923	1170	1445	1750	2084	2448	1450	1838	2271	2750	3275	3846	4463	5126	5825	6480
	328	521	778	1107	1445	1750	2084	2448	1222	1740	2271	2750	3275	3846	4463	5126	5825	6480
	1.5	3	3	3	4.5	4.5	6	6	3	3	4.5	4.5	6	6	7.5	7.5	9	10.5
12'	371	591	774	981	1212	1468	1749	2054	1216	1541	1905	2307	2748	3228	3746	4291	4868	5481
	253	401	599	853	1170	1468	1749	2054	941	1340	1839	2307	2748	3228	3746	4291	4868	5481
	1.5	1.5	3	3	3	4.5	4.5	6	3	3	3	4.5	4.5	6	6	7.5	9	9
13'	290	464	658	834	1031	1249	1488	1748	1034	1311	1620	1963	2338	2746	3177	3637	4126	4646
	199	316	471	671	920	1225	1488	1748	740	1054	1446	1925	2338	2746	3177	3637	4126	4646
	1.5	1.5	3	3	3	4.5	4.5	6	3	3	3	4.5	4.5	6	6	7.5	7.5	9
14'	231	370	555	718	887	1075	1281	1505	873	1128	1394	1689	2013	2357	2725	3120	3540	3987
	159	253	377	537	737	981	1273	1505	593	844	1158	1541	2001	2357	2725	3120	3540	3987
	1.5	1.5	3	3	3	3	4.5	4.5	3	3	3	3	4.5	4.5	6	6	7.5	7.5
15'	186	299	450	624	771	935	1114	1308	707	980	1212	1469	1745	2042	2362	2704	3069	3456
	129	205	307	437	599	797	1035	1308	482	686	941	1253	1627	2042	2362	2704	3069	3456
	1.5	1.5	1.5	3	3	3	4.5	4.5	1.5	3	3	3	4.5	4.5	6	6	7.5	7.5
16'	152	245	369	528	676	820	977	1148	579	830	1063	1286	1526	1786	2066	2365	2685	3024
	107	169	253	360	494	657	853	1085	397	565	776	1032	1340	1704	2066	2365	2685	3024
	1.5	1.5	1.5	3	3	3	4.5	4.5	1.5	3	3	3	4.5	4.5	6	6	7.5	7.5
17'	126	203	306	438	598	724	864	1015	480	689	939	1133	1345	1574	1821	2085	2367	2666
	89	141	211	300	412	548	711	904	331	471	647	861	1118	1421	1775	2085	2367	2666
	1.5	1.5	1.5	1.5	3	3	3	4.5	1.5	1.5	3	3	3	4.5	4.5	6	6	6
18'	105	169	256	367	507	645	769	903	402	577	797	1005	1193	1397	1616	1851	2102	2367
	75	119	178	253	347	461	599	762	279	397	545	725	941	1197	1495	1839	2102	2367
	1.5	1.5	1.5	1.5	3	3	3	4.5	1.5	1.5	3	3	3	4.5	4.5	6	6	6
19'	88	143	216	311	429	574	688	809	339	488	674	898	1066	1248	1444	1654	1878	2115
	64	101	151	215	295	392	509	648	237	338	463	617	800	1018	1271	1563	1878	2115
	1.5	1.5	1.5	1.5	3	3	3	4.5	1.5	1.5	3	3	3	3	4.5	4.5	4.5	6
20'	74	121	184	265	366	490	620	729	289	416	575	770	957	1121	1297	1486	1687	1901
	55	87	129	184	253	336	437	555	203	290	397	529	686	873	1090	1340	1627	1901
	1.5	1.5	1.5	1.5	1.5	3	3	3	1.5	1.5	1.5	3	3	3	4.5	4.5	4.5	6
21'	63	103	157	227	314	422	550	659	247	357	494	662	863	1011	1171	1341	1523	1717
	47	75	112	159	218	291	377	480	176	250	343	457	593	754	941	1158	1405	1686
	1.5	1.5	1.5	1.5	1.5	3	3	3	1.5	1.5	1.5	3	3	3	4.5	4.5	4.5	6
22'	54	89	135	196	272	365	477	597	213	308	427	573	749	917	1062	1217	1382	1557
	41	65	97	138	190	253	328	417	153	218	298	397	516	656	819	1007	1222	1466
	1.5	1.5	1.5	1.5	1.5	3	3	3	1.5	1.5	1.5	3	3	3	3	4.5	4.5	4.5
23'	46	76	117	170	236	317	415	531	184	267	371	499	652	834	967	1108	1259	1419
	36	57	85	121	166	221	287	365	134	190	261	348	451	574	717	881	1070	1283
	1.5	1.5	1.5	1.5	1.5	1.5	3	3	1.5	1.5	1.5	1.5	3	3	3	4.5	4.5	4.5
24'	40	66	102	148	206	278	363	465	160	233	324	436	571	731	883	1013	1151	1297
	32	50	75	107	146	195	253	321	118	168	230	306	397	505	631	776	941	1129
	1.5	1.5	1.5	1.5	1.5	1.5	3	3	1.5	1.5	1.5	1.5	3	3	3	4.5	4.5	4.5
25'	34	57	89	130	181	244	320	410	140	204	285	383	502	644	808	929	1056	1190
	28	44	66	94	129	172	224	284	104	148	203	271	351	447	558	686	833	999
	1.5	1.5	1.5	1.5	1.5	1.5	3	3	1.5	1.5	1.5	1.5	3	3	3	3	4.5	4.5
26'	29	50	78	114	160	215	283	362	122	179	251	338	444	569	715	855	972	1096
	25	39	59	84	115	153	199	253	93	132	181	241	312	397	496	610	740	888
	1.5	1.5	1.5	1.5	1.5	1.5	1.5	3	1.5	1.5	1.5	1.5	1.5	3	3	3	4.5	4.5
27'	25	44	68	101	141	191	251	322	108	158	222	300	394	505	636	786	897	1011
	22	35	53	75	103	137	178	226	83	118	161	215	279	355	443	545	661	793
	1.5	1.5	1.5	1.5	1.5	1.5	1.5	3	1.5	1.5	1.5	1.5	1.5	3	3	3	4.5	4.5
28'	22	38	60	89	125	170	223	287	95	140	197	266	351	450	567	702	830	936
	20	32	47	67	92	123	159	202	74	106	145	193	250	318	397	488	593	711
	1.5	1.5	1.5	1.5	1.5	1.5	1.5	3	1.5	1.5	1.5	1.5	1.5	3	3	3	3	4.5
29'	19	34	53	79	111	151	199	256	84	124	175	238	313	403	508	629	768	869
	18	28	42	60	83	110	143	182	67	95	130	173	225	286	357	440	534	640
	1.5	1.5	1.5	1.5	1.5	1.5	1.5	3	1.5	1.5	1.5	1.5	1.5	3	3	3	3	4.5
30'	16	29	47	70	99	135	178	230	74	110	156	212	280	361	456	565	690	808
	16	26	38	55	75	100	129	165	60	86	118	157	203	259	323	397	482	578
	1.5																	

Allowable Roof Load Tables LDF=1.15

3-1/2" & 5-1/2" Widths - Standard Depths

Key - for each clear span there are three numbers:

- Row 1: Maximum Total Load with LDF of 1.15, and deflection limited to L/180
- Row 2: Maximum Live Load limited by deflection of L/240
- Row 3: Required Bearing Length in trimmer thickness (e.g., 1.5 = 1 trimmer, 3.0 = 2 trimmers, etc.)

These tables can be used to size simple span beams and headers that carry uniform loads. The PLF loads must be calculated and take into account all floor and roof framing loads coming onto the beam or header.

Allowable Loads for Anthony Glulam in Pounds per Linear Foot

Actual Span	3 1/2"							5 1/2"										
	Depth (in.)							Depth (in.)										
	8 1/4	9 5/8	11	12 3/8	13 3/4	15 1/8	16 1/2	17 7/8	11	12 3/8	13 3/4	15 1/8	16 1/2	17 7/8	19 1/4	20 5/8	22	23 3/8
6'	2021	2753	3597	4542	5360	6285	7341	8557	3597	7138	8422	9876	11536	13447	15672	18296	21436	25260
	2021	2753	3597	4542	5360	6285	7341	8557	3597	7138	8422	9876	11536	13447	15672	18296	21436	25260
	3	4.5	4.5	6	7.5	9	10.5	12	4.5	6	7.5	9	10.5	12	13.5	16.5	19.5	24
7'	1483	2020	2640	3343	4128	4879	5610	6425	2640	5253	6487	7666	8816	10096	11531	13152	14995	17111
	1483	2020	2640	3343	4128	4879	5610	6425	2640	5253	6487	7666	8816	10096	11531	13152	14995	17111
	3	3	4.5	6	6	7.5	9	10.5	4.5	6	6	7.5	9	10.5	12	13.5	15	18
8'	1134	1545	2019	2557	3158	3822	4538	5142	2019	4017	4962	6006	7132	8080	9119	10263	11527	12934
	1134	1545	2019	2557	3158	3822	4538	5142	2019	4017	4962	6006	7132	8080	9119	10263	11527	12934
	3	3	4.5	4.5	6	7.5	9	9	4.5	4.5	6	7.5	9	9	10.5	12	13.5	15
9'	894	1218	1593	2018	2492	3017	3592	4217	1593	3170	3916	4741	5644	6627	7539	8412	9360	10393
	894	1218	1593	2018	2492	3017	3592	4217	1593	3170	3916	4741	5644	6627	7539	8412	9360	10393
	3	3	3	4.5	6	6	7.5	9	3	4.5	6	6	7.5	9	9	10.5	12	13.5
10'	723	985	1288	1632	2016	2441	2907	3413	1288	2565	3168	3836	4567	5363	6221	7126	7877	8685
	655	985	1288	1632	2016	2441	2907	3413	1288	2565	3168	3836	4567	5363	6221	7126	7877	8685
	1.5	3	3	4.5	4.5	6	6	7.5	3	4.5	4.5	6	6	7.5	9	10.5	10.5	12
11'	596	813	1063	1347	1664	2015	2399	2817	1063	2116	2615	3166	3770	4427	5137	5899	6704	7457
	492	782	1063	1347	1664	2015	2399	2817	1063	2116	2615	3166	3770	4427	5137	5899	6704	7457
	1.5	3	3	3	4.5	4.5	6	7.5	3	3	4.5	4.5	6	7.5	7.5	9	10.5	12
12'	498	681	891	1130	1396	1691	2014	2365	891	1775	2194	2657	3164	3716	4312	4939	5603	6308
	379	602	891	1130	1396	1691	2014	2365	891	1775	2194	2657	3164	3716	4312	4939	5603	6308
	1.5	3	3	3	4.5	4.5	6	6	3	3	4.5	4.5	6	6	7.5	9	9	10.5
13'	390	579	758	961	1188	1439	1713	2012	758	1510	1866	2261	2693	3162	3658	4187	4750	5348
	298	473	707	961	1188	1439	1713	2012	707	1510	1866	2261	2693	3162	3658	4187	4750	5348
	1.5	1.5	3	3	4.5	4.5	6	6	3	3	4.5	4.5	6	6	7.5	7.5	9	10.5
14'	310	496	652	827	1022	1238	1475	1733	652	1299	1606	1946	2318	2714	3138	3592	4076	4590
	239	379	566	806	1022	1238	1475	1733	566	1266	1606	1946	2318	2714	3138	3592	4076	4590
	1.5	1.5	3	3	3	4.5	4.5	6	3	3	3	4.5	4.5	6	6	7.5	7.5	9
15'	251	402	567	719	889	1077	1283	1507	567	1130	1397	1692	2011	2353	2721	3114	3534	3980
	194	308	460	655	889	1077	1283	1507	460	1029	1397	1692	2011	2353	2721	3114	3534	3980
	1.5	1.5	3	3	3	4.5	4.5	4.5	3	3	3	4.5	4.5	6	6	7.5	7.5	9
16'	205	330	495	630	780	945	1126	1323	495	991	1225	1482	1759	2058	2380	2725	3092	3482
	160	254	379	540	740	945	1126	1323	379	848	1164	1482	1759	2058	2380	2725	3092	3482
	1.5	1.5	3	3	3	4.5	4.5	4.5	3	3	3	4.5	4.5	6	6	7.5	7.5	9
17'	170	273	411	557	689	835	995	1170	411	875	1083	1307	1550	1814	2098	2403	2727	3071
	133	212	316	450	617	822	995	1170	316	707	970	1291	1550	1814	2098	2403	2727	3071
	1.5	1.5	1.5	3	3	3	4.5	4.5	1.5	3	3	4.5	4.5	6	6	6	7.5	7.5
18'	142	229	345	494	613	744	886	1042	345	776	961	1160	1376	1611	1863	2134	2422	2728
	112	178	266	379	520	692	886	1042	266	596	817	1088	1376	1611	1863	2134	2422	2728
	1.5	1.5	1.5	3	3	3	4.5	4.5	1.5	3	3	4.5	4.5	6	6	6	7.5	7.5
19'	120	193	291	418	549	666	794	933	291	657	858	1036	1229	1439	1665	1907	2164	2438
	96	152	226	322	442	589	764	933	226	507	695	925	1201	1439	1665	1907	2164	2438
	1.5	1.5	1.5	3	3	3	4.5	4.5	1.5	3	3	3	3	4.5	4.5	6	6	6
20'	101	164	248	357	492	600	715	840	248	561	770	930	1104	1293	1496	1713	1945	2191
	82	130	194	276	379	505	655	833	194	434	596	793	1029	1293	1496	1713	1945	2191
	1.5	1.5	1.5	1.5	3	3	4.5	4.5	1.5	1.5	3	3	3	4.5	4.5	6	6	6
21'	86	141	213	307	424	542	647	760	213	482	666	839	997	1167	1351	1547	1757	1979
	71	112	168	239	327	436	566	719	168	375	515	685	889	1131	1351	1547	1757	1979
	1.5	1.5	1.5	1.5	3	3	4.5	4.5	1.5	1.5	3	3	3	4.5	4.5	6	6	6
22'	74	121	184	265	367	491	588	689	184	417	576	761	904	1058	1225	1404	1594	1796
	62	98	146	208	285	379	492	626	146	326	448	596	773	983	1225	1404	1594	1796
	1.5	1.5	1.5	1.5	3	3	3	3	1.5	1.5	3	3	3	3	4.5	4.5	4.5	6
23'	64	105	160	231	319	428	536	628	160	362	502	673	823	964	1116	1279	1452	1637
	54	85	128	182	249	332	431	548	128	286	392	521	677	861	1075	1279	1452	1637
	1.5	1.5	1.5	1.5	1.5	3	3	3	1.5	1.5	1.5	3	3	3	4.5	4.5	4.5	6
24'	55	91	139	202	279	375	490	574	139	317	439	589	752	881	1020	1169	1328	1497
	47	75	112	160	219	292	379	482	112	251	345	459	596	757	946	1164	1328	1497
	1.5	1.5	1.5	1.5	1.5	3	3	3	1.5	1.5	1.5	3	3	3	4.5	4.5	4.5	4.5
25'	48	80	122	177	246	330	432	527	122	278	386	519	678	808	936	1073	1219	1374
	42	67	99	142	194	258	335	426	99	222	305	406	527	670	837	1029	1219	1374
	1.5	1.5	1.5	1.5	1.5	3	3	3	1.5	1.5	1.5	3	3	3	4.5	4.5	4.5	4.5
26'	42	70	107	156	217	292	382	485	107	245	341	459	600	744	862	988	1122	1265
	37	59	88	126	173	230	298	379	88	198	271	361	469	596	744	915	1111	1265
	1.5	1.5	1.5	1.5	1.5	1.5	3	3	1.5	1.5	1.5	1.5	3	3	3	4.5	4.5	4.5
27'	37	61	95	138	192	259	339	434	95	217	302	407	533	683	795	912	1036	1168
	33	53	79	112	154	205	266	339	79	177	242	322	418	532	664	817	992	1168
	1.5	1.5	1.5	1.5	1.5	1.5	3	3	1.5	1.5	1.5	1.5	3	3	3	4.5	4.5	4.5
28'	32	54	84	123	171	231	303	388	84	193	269	363	476	609	736	844	959	1082
	30	47	71	101	138	184	239	304	71	158	217	289	375	477	596	733	889	1067
	1.5	1.5	1.5	1.5	1.5	1.5	3	3	1.5	1.5	1.5	1.5	3	3	3	3	4.5	4.5
29'	28	48	74	109	153	206	271	347	74	172	240	324	426	546	683	783	891	1004
	27	43	64	91	124	166	215	273	64	142	195	260	338	429	536	660	800	960
	1.5	1.5	1.5	1.5	1.5	1.5	3	3	1.5	1.5	1.5	1.5	3	3	3	3	4.5	4.5
30'	25	42	66	97	137	185	243	312	66									

Allowable Roof Load Tables LDF=1.25

3-1/2" & 5-1/2" Widths - Standard Depths

Key - for each clear span there are three numbers:

- Row 1: Maximum Total Load with LDF of 1.25, and deflection limited to L/180
- Row 2: Maximum Live Load limited by deflection of L/240
- Row 3: Required Bearing Length in trimmer thickness (e.g., 1.5 = 1 trimmer, 3.0 = 2 trimmers, etc.)

These tables can be used to size simple span beams and headers that carry uniform loads. The PLF loads must be calculated and take into account all floor and roof framing loads coming onto the beam or header.

Allowable Loads for Anthony Glulam in Pounds per Linear Foot

Actual Span	3 1/2"							5 1/2"										
	Depth (in.)							Depth (in.)										
	8 1/4	9 5/8	11	12 3/8	13 3/4	15 1/8	16 1/2	17 7/8	11	12 3/8	13 3/4	15 1/8	16 1/2	17 7/8	19 1/4	20 5/8	22	23 3/8
6'	2198	2993	3911	4938	5827	6833	7981	9303	3911	7760	9156	10737	12541	14619	17038	19890	23303	27460
	2198	2993	3911	4938	5827	6833	7981	9303	3911	7760	9156	10737	12541	14619	17038	19890	23303	27460
	3	4.5	6	7.5	7.5	9	10.5	13.5	6	7.5	7.5	9	10.5	13.5	15	18	22.5	27
7'	1613	2197	2871	3634	4488	5304	6099	6985	2871	5711	7053	8335	9584	10976	12537	14298	16302	18602
	1613	2197	2871	3634	4488	5304	6099	6985	2871	5711	7053	8335	9584	10976	12537	14298	16302	18602
	3	4.5	4.5	6	7.5	9	10.5	12	4.5	6	7.5	9	10.5	12	13.5	15	16.5	19.5
8'	1233	1680	2195	2780	3433	4156	4934	5590	2195	4368	5395	6531	7754	8785	9914	11158	12533	14061
	1233	1680	2195	2780	3433	4156	4934	5590	2195	4368	5395	6531	7754	8785	9914	11158	12533	14061
	3	3	4.5	4.5	6	7.5	9	10.5	4.5	4.5	6	7.5	9	10.5	12	13.5	15	16.5
9'	973	1325	1732	2194	2710	3281	3906	4585	1732	3448	4259	5155	6137	7205	8198	9146	10177	11300
	899	1325	1732	2194	2710	3281	3906	4585	1732	3448	4259	5155	6137	7205	8198	9146	10177	11300
	3	3	4.5	4.5	6	7.5	7.5	9	4.5	4.5	6	7.5	7.5	9	10.5	12	13.5	15
10'	786	1072	1401	1775	2193	2655	3161	3711	1401	2789	3446	4172	4967	5831	6765	7748	8565	9443
	655	1040	1401	1775	2193	2655	3161	3711	1401	2789	3446	4172	4967	5831	6765	7748	8565	9443
	3	3	3	4.5	4.5	6	7.5	9	3	4.5	4.5	6	7.5	9	9	10.5	12	13.5
11'	648	884	1156	1465	1810	2191	2609	3064	1156	2302	2844	3444	4100	4815	5586	6415	7290	8109
	492	782	1156	1465	1810	2191	2609	3064	1156	2302	2844	3444	4100	4815	5586	6415	7290	8109
	1.5	3	3	4.5	4.5	6	6	7.5	3	4.5	4.5	6	6	7.5	9	10.5	12	12
12'	498	741	970	1229	1519	1839	2190	2572	970	1931	2387	2890	3442	4041	4689	5371	6093	6860
	379	602	899	1229	1519	1839	2190	2572	899	1931	2387	2890	3442	4041	4689	5371	6093	6860
	1.5	3	3	3	4.5	4.5	6	7.5	3	3	4.5	4.5	6	7.5	7.5	9	10.5	12
13'	390	622	825	1045	1292	1565	1864	2189	825	1643	2030	2459	2929	3440	3978	4553	5166	5817
	298	473	707	1006	1292	1565	1864	2189	707	1581	2030	2459	2929	3440	3978	4553	5166	5817
	1.5	3	3	3	4.5	4.5	6	6	3	3	4.5	4.5	6	6	7.5	9	9	10.5
14'	310	496	710	900	1112	1347	1605	1885	710	1414	1748	2117	2522	2953	3414	3907	4433	4992
	239	379	566	806	1105	1347	1605	1885	566	1266	1737	2117	2522	2953	3414	3907	4433	4992
	1.5	1.5	3	3	4.5	4.5	4.5	6	3	3	4.5	4.5	4.5	6	7.5	7.5	9	10.5
15'	251	402	603	782	967	1172	1396	1640	603	1229	1520	1841	2188	2560	2960	3388	3844	4329
	194	308	460	655	899	1172	1396	1640	460	1029	1412	1841	2188	2560	2960	3388	3844	4329
	1.5	1.5	3	3	3	4.5	4.5	6	3	3	3	4.5	4.5	6	6	7.5	7.5	9
16'	205	330	495	686	849	1028	1225	1439	495	1078	1333	1613	1914	2239	2589	2964	3364	3788
	160	254	379	540	740	986	1225	1439	379	848	1164	1549	1914	2239	2589	2964	3364	3788
	1.5	1.5	3	3	3	4.5	4.5	6	3	3	3	4.5	4.5	6	6	7.5	7.5	9
17'	170	273	411	588	750	909	1083	1273	411	924	1179	1422	1687	1974	2283	2614	2967	3341
	133	212	316	450	617	822	1067	1273	316	707	970	1291	1676	1974	2283	2614	2967	3341
	1.5	1.5	1.5	3	3	4.5	4.5	4.5	1.5	3	3	4.5	4.5	4.5	6	6	7.5	7.5
18'	142	229	345	494	668	809	965	1134	345	776	1047	1262	1498	1753	2028	2322	2635	2968
	112	178	266	379	520	692	899	1134	266	596	817	1088	1412	1753	2028	2322	2635	2968
	1.5	1.5	1.5	3	3	3	4.5	4.5	1.5	3	3	3	4.5	4.5	6	6	6	7.5
19'	120	193	291	418	577	725	864	1016	291	657	906	1128	1338	1566	1812	2075	2355	2653
	96	152	226	322	442	589	764	971	226	507	695	925	1201	1527	1812	2075	2355	2653
	1.5	1.5	1.5	3	3	3	4.5	4.5	1.5	3	3	3	4.5	4.5	6	6	6	7.5
20'	101	164	248	357	492	653	778	915	248	561	774	1013	1202	1407	1628	1865	2117	2385
	82	130	194	276	379	505	655	833	194	434	596	793	1029	1309	1628	1865	2117	2385
	1.5	1.5	1.5	1.5	3	3	4.5	4.5	1.5	1.5	3	3	3	4.5	4.5	6	6	7.5
21'	86	141	213	307	424	567	705	828	213	482	666	891	1085	1271	1471	1684	1912	2154
	71	112	168	239	327	436	566	719	168	375	515	685	889	1131	1412	1684	1912	2154
	1.5	1.5	1.5	1.5	3	3	3	4.5	1.5	1.5	3	3	3	4.5	4.5	6	6	6
22'	74	121	184	265	367	491	641	751	184	417	576	772	984	1153	1334	1528	1735	1955
	62	98	146	208	285	379	492	626	146	326	448	596	773	983	1228	1511	1735	1955
	1.5	1.5	1.5	1.5	3	3	3	4.5	1.5	1.5	3	3	3	4.5	4.5	6	6	6
23'	64	105	160	231	319	428	559	684	160	362	502	673	878	1050	1215	1393	1581	1782
	54	85	128	182	249	332	431	548	128	286	392	521	677	861	1075	1322	1581	1782
	1.5	1.5	1.5	1.5	1.5	3	3	4.5	1.5	1.5	1.5	3	3	3	4.5	4.5	6	6
24'	55	91	139	202	279	375	490	625	139	317	439	589	770	960	1112	1274	1447	1630
	47	75	112	160	219	292	379	482	112	251	345	459	596	757	946	1164	1412	1630
	1.5	1.5	1.5	1.5	1.5	3	3	3	1.5	1.5	1.5	3	3	3	4.5	4.5	4.5	6
25'	48	80	122	177	246	330	432	552	122	278	386	519	678	867	1020	1169	1328	1497
	42	67	99	142	194	258	335	426	99	222	305	406	527	670	837	1029	1249	1497
	1.5	1.5	1.5	1.5	1.5	3	3	3	1.5	1.5	1.5	3	3	3	4.5	4.5	4.5	6
26'	42	70	107	156	217	292	382	489	107	245	341	459	600	768	939	1076	1223	1378
	37	59	88	126	173	230	298	379	88	198	271	361	469	596	744	915	1111	1332
	1.5	1.5	1.5	1.5	1.5	1.5	3	3	1.5	1.5	1.5	1.5	3	3	4.5	4.5	4.5	4.5
27'	37	61	95	138	192	259	339	434	95	217	302	407	533	683	857	994	1129	1273
	33	53	79	112	154	205	266	339	79	177	242	322	418	532	664	817	992	1190
	1.5	1.5	1.5	1.5	1.5	1.5	3	3	1.5	1.5	1.5	1.5	3	3	3	4.5	4.5	4.5
28'	32	54	84	123	171	231	303	388	84	193	269	363	476	609	766	920	1046	1179
	30	47	71	101	138	184	239	304	71	158	217	289	375	477	596	733	889	1067
	1.5	1.5	1.5	1.5	1.5	1.5	3	3	1.5	1.5	1.5	1.5	3	3	3	4.5	4.5	4.5
29'	28	48	74	109	153	206	271	347	74	172	240	324	426	546	686	849	971	1095
	27	43	64	91	124	166	215	273	64	142	195	260	338	429	536	660	800	960
	1.5	1.5	1.5	1.5	1.5	1.5	3	3	1.5	1.5	1.5	1.5	3	3	3	4.5	4.5	4.5
30'	25	42	66	97	137	185	243	312	66	153	215	291	382	490	617	764	904	1019
	24	39	58	82	112	150												

Allowable Floor Load Tables LDF=1.00 6-3/4" Widths - Standard Depths

Key - for each clear span there are three numbers:

- Row 1: Maximum Total Load with LDF of 1.0, and deflection limited to L/240
- Row 2: Maximum Live Load limited by deflection of L/360
- Row 3: Required Bearing Length in trimmer thickness (e.g., 1.5 = 1 trimmer, 3.0 = 2 trimmers, etc.)

These tables can be used to size simple span beams and headers that carry uniform loads. The PLF loads must be calculated and take into account all floor and roof framing loads coming onto the beam or header.

Allowable Loads for Anthony Glulam in Pounds per Linear Foot

Actual Span	6 3/4"															
	Depth (in.)															
	8 1/4	9 5/8	11	12 3/8	13 3/4	15 1/8	16 1/2	17 7/8	19 1/4	20 5/8	22	23 3/8	24 3/4	26 1/8	27 1/2	28 7/8
6'	3388	4614	6030	7615	8985	10536	12307	14346	16721	19521	22871	26952	30583	34078	37762	41635
	3388	4614	6030	7615	8985	10536	12307	14346	16721	19521	22871	26952	30583	34078	37762	41635
	3	3	4.5	6	6	7.5	9	10.5	12	15	16.5	21	24	27	31.5	34.5
7'	2485	3386	4425	5603	6920	8178	9404	10770	12302	14031	15998	18256	20874	23946	27601	30491
	2456	3386	4425	5603	6920	8178	9404	10770	12302	14031	15998	18256	20874	23946	27601	30491
	3	3	4.5	4.5	6	7.5	7.5	9	10.5	12	13.5	15	18	21	24	27
8'	1899	2588	3383	4284	5292	6406	7607	8619	9727	10947	12297	13797	15475	17365	19508	21960
	1645	2588	3383	4284	5292	6406	7607	8619	9727	10947	12297	13797	15475	17365	19508	21960
	3	3	3	4.5	4.5	6	7.5	7.5	9	10.5	12	13.5	15	16.5	19.5	21
9'	1497	2041	2669	3381	4176	5056	6020	7068	8041	8972	9984	11086	12292	13617	15080	16703
	1155	1835	2669	3381	4176	5056	6020	7068	8041	8972	9984	11086	12292	13617	15080	16703
	1.5	3	3	4.5	4.5	6	6	7.5	9	9	10.5	12	13.5	15	16.5	18
10'	1210	1650	2158	2734	3378	4090	4870	5719	6633	7591	8401	9263	10192	11197	12287	13473
	842	1337	1997	2734	3378	4090	4870	5719	6633	7591	8401	9263	10192	11197	12287	13473
	1.5	3	3	3	4.5	4.5	6	7.5	7.5	9	10.5	10.5	12	13.5	15	16.5
11'	934	1361	1780	2256	2787	3375	4020	4714	5449	6237	7076	7953	8703	9505	10364	11287
	633	1005	1500	2136	2787	3375	4020	4714	5449	6237	7076	7953	8703	9505	10364	11287
	1.5	3	3	3	4.5	4.5	6	6	7.5	7.5	9	10.5	10.5	12	13.5	15
12'	716	1140	1492	1892	2338	2832	3367	3939	4553	5212	5913	6658	7445	8255	8960	9709
	487	774	1155	1645	2257	2832	3367	3939	4553	5212	5913	6658	7445	8255	8960	9709
	1.5	1.5	3	3	3	4.5	4.5	6	6	7.5	7.5	9	10.5	12	12	13.5
13'	560	896	1269	1608	1989	2406	2853	3338	3859	4417	5012	5644	6312	7016	7757	8517
	383	609	909	1294	1775	2362	2853	3338	3859	4417	5012	5644	6312	7016	7757	8517
	1.5	1.5	3	3	3	4.5	4.5	6	6	7.5	7.5	9	9	10.5	12	12
14'	445	714	1071	1384	1711	2063	2447	2863	3310	3789	4300	4842	5416	6020	6656	7323
	307	487	728	1036	1421	1891	2447	2863	3310	3789	4300	4842	5416	6020	6656	7323
	1.5	1.5	3	3	3	3	4.5	4.5	6	6	7.5	7.5	9	9	10.5	12
15'	359	577	867	1203	1482	1787	2120	2481	2869	3285	3728	4198	4695	5220	5772	6350
	250	396	592	842	1155	1538	1997	2481	2869	3285	3728	4198	4695	5220	5772	6350
	1.5	1.5	1.5	3	3	3	4.5	4.5	6	6	7.5	7.5	9	10.5	10.5	10.5
16'	293	472	711	1018	1295	1562	1854	2169	2509	2873	3261	3672	4108	4567	5050	5557
	206	327	487	694	952	1267	1645	2092	2509	2873	3261	3672	4108	4567	5050	5557
	1.5	1.5	1.5	3	3	3	4.5	4.5	6	6	7.5	7.5	9	9	10.5	10.5
17'	242	391	589	845	1141	1376	1633	1912	2212	2533	2875	3238	3623	4028	4454	4901
	171	272	406	579	794	1056	1372	1744	2178	2533	2875	3238	3623	4028	4454	4901
	1.5	1.5	1.5	1.5	3	3	4.5	4.5	6	6	7.5	7.5	9	9	10.5	10.5
18'	202	326	493	709	978	1221	1449	1697	1963	2249	2553	2875	3217	3577	3956	4353
	144	229	342	487	669	890	1155	1469	1835	2249	2553	2875	3217	3577	3956	4353
	1.5	1.5	1.5	1.5	3	3	3	4.5	4.5	6	6	7.5	7.5	9	9	10.5
19'	169	275	417	599	828	1090	1294	1515	1754	2009	2281	2569	2875	3197	3536	3891
	123	195	291	414	569	757	982	1249	1560	1919	2281	2569	2875	3197	3536	3891
	1.5	1.5	1.5	1.5	3	3	3	4.5	4.5	6	6	7.5	7.5	9	9	10.5
20'	143	233	354	510	706	945	1162	1361	1575	1804	2049	2309	2583	2873	3178	3498
	105	167	250	355	487	649	842	1071	1337	1645	1997	2309	2583	2873	3178	3498
	1.5	1.5	1.5	1.5	3	3	3	4.5	4.5	6	6	7.5	7.5	9	9	10.5
21'	121	199	303	438	606	813	1049	1228	1422	1629	1850	2085	2333	2595	2871	3160
	91	144	216	307	421	560	728	925	1155	1421	1725	2069	2333	2595	2871	3160
	1.5	1.5	1.5	1.5	3	3	3	4.5	4.5	6	6	7.5	7.5	9	9	10.5
22'	104	171	261	378	524	703	919	1114	1289	1477	1678	1891	2117	2355	2605	2867
	79	126	188	267	366	487	633	805	1005	1236	1500	1799	2117	2355	2605	2867
	1.5	1.5	1.5	1.5	3	3	3	4.5	4.5	6	6	7.5	7.5	9	9	10.5
23'	89	147	226	328	456	612	801	1014	1174	1346	1528	1723	1929	2145	2374	2613
	69	110	164	234	320	427	554	704	879	1082	1313	1575	1869	2145	2374	2613
	1.5	1.5	1.5	1.5	3	3	3	4.5	4.5	6	6	7.5	7.5	9	9	10.5
24'	76	128	197	286	398	536	701	897	1073	1230	1397	1575	1764	1962	2171	2390
	61	97	144	206	282	375	487	620	774	952	1155	1386	1645	1935	2171	2390
	1.5	1.5	1.5	1.5	3	3	3	4.5	4.5	6	6	7.5	7.5	9	9	10.5
25'	66	111	172	250	349	471	617	790	984	1128	1282	1445	1618	1801	1993	2194
	54	86	128	182	250	332	431	548	685	842	1022	1226	1455	1712	1993	2194
	1.5	1.5	1.5	1.5	3	3	3	4.5	4.5	6	6	7.5	7.5	9	9	10.5
26'	57	97	150	220	308	415	545	698	878	1038	1180	1330	1490	1658	1835	2021
	48	76	114	162	222	295	383	487	609	749	909	1090	1294	1522	1775	2021
	1.5	1.5	1.5	1.5	3	3	3	4.5	4.5	6	6	7.5	7.5	9	9	10.5
27'	49	84	132	194	272	368	483	620	780	958	1089	1228	1376	1531	1695	1866
	43	68	101	144	198	264	342	435	544	669	811	973	1155	1359	1585	1835
	1.5	1.5	1.5	1.5	3	3	3	4.5	4.5	6	6	7.5	7.5	9	9	10.5
28'	42	74	116	172	241	327	430	553	696	862	1008	1137	1273	1418	1569	1728
	38	61	91	129	178	236	307	390	487	600	728	873	1036	1218	1421	1645
	1.5	1.5	1.5	1.5	3	3	3	4.5	4.5	6	6	7.5	7.5	9	9	10.5
29'	37	65	103	152	215	292	384	494	623	772	935	1055	1182	1316	1457	1605
	35	55	82	117	160	213	276	351	439	540	655	786	932	1097	1279	1481
	1.5	1.5	1.5	1.5	3	3	3	4.5	4.5	6	6	7.5	7.5	9	9	10.5
30'	32	57	91	135	191	261	344	443	559	693	847	981	1100	1224	1356	1493
	31	50	74	105	144	192	250	317	396	487	592	710	842	991	1155	1337
	1.5	1.5	1.5	1.5	3	3	3	4.5	4.5	6	6	7.5	7.5	9	9	10.5
32'	23	44	71	108	153	210	278	359	455	565	691	834	958	1067	1181	1302
	23	41	61	87	119	158	206	261	327	402	487	585	694	816	952	1102
	1.5	1.5	1.5	1.5	3	3	3	4.5	4.5	6	6	7.5	7.5	9	9	10.5

Allowable Roof Load Tables LDF=1.15

6-3/4" Widths - Standard Depths

Key - for each clear span there are three numbers:

- Row 1: Maximum Total Load with LDF of 1.15, and deflection limited to L/180
- Row 2: Maximum Live Load limited by deflection of L/240
- Row 3: Required Bearing Length in trimmer thickness (e.g., 1.5 = 1 trimmer, 3.0 = 2 trimmers, etc.)

These tables can be used to size simple span beams and headers that carry uniform loads. The PLF loads must be calculated and take into account all floor and roof framing loads coming onto the beam or header.

Allowable Loads for Anthony Glulam in Pounds per Linear Foot

Actual Span	6 3/4"															
	Depth (in.)															
	8 1/4	9 5/8	11	12 3/8	13 3/4	15 1/8	16 1/2	17 7/8	19 1/4	20 5/8	22	23 3/8	24 3/4	26 1/8	27 1/2	28 7/8
6'	3899	5309	6937	8760	10336	12121	14157	16503	19234	22455	26308	31001	35177	39197	43434	47889
	3899	5309	6937	8760	10336	12121	14157	16503	19234	22455	26308	31001	35177	39197	43434	47889
	3	4.5	4.5	6	7.5	9	10.5	12	13.5	16.5	19.5	24	28.5	31.5	36	42
7'	2860	3896	5092	6447	7962	9409	10819	12391	14152	16141	18403	21000	24012	27545	31749	35073
	2860	3896	5092	6447	7962	9409	10819	12391	14152	16141	18403	21000	24012	27545	31749	35073
	3	3	4.5	6	6	7.5	9	10.5	12	13.5	15	18	21	24	28.5	33
8'	2186	2979	3893	4931	6090	7371	8753	9916	11191	12595	14147	15873	17803	19977	22442	25262
	2186	2979	3893	4931	6090	7371	8753	9916	11191	12595	14147	15873	17803	19977	22442	25262
	3	3	4.5	4.5	6	7.5	9	9	10.5	12	13.5	15	16.5	19.5	22.5	25.5
9'	1724	2350	3072	3891	4806	5819	6927	8133	9253	10324	11487	12755	14142	15667	17349	19217
	1724	2350	3072	3891	4806	5819	6927	8133	9253	10324	11487	12755	14142	15667	17349	19217
	3	3	3	4.5	6	6	7.5	9	9	10.5	12	13.5	15	16.5	18	21
10'	1394	1900	2485	3147	3888	4708	5605	6581	7633	8735	9667	10658	11727	12883	14137	15502
	1263	1900	2485	3147	3888	4708	5605	6581	7633	8735	9667	10658	11727	12883	14137	15502
	1.5	3	3	4.5	4.5	6	6	7.5	9	10.5	12	13.5	15	15	16.5	18
11'	1149	1567	2050	2597	3209	3886	4627	5426	6272	7178	8143	9152	10015	10938	11926	12988
	949	1507	2050	2597	3209	3886	4627	5426	6272	7178	8143	9152	10015	10938	11926	12988
	1.5	3	3	3	4.5	4.5	6	7.5	7.5	9	10.5	12	12	13.5	15	16.5
12'	960	1314	1719	2179	2693	3261	3877	4534	5242	5999	6806	7663	8569	9501	10311	11174
	731	1161	1719	2179	2693	3261	3877	4534	5242	5999	6806	7663	8569	9501	10311	11174
	1.5	3	3	3	4.5	4.5	6	6	7.5	9	9	10.5	12	13.5	13.5	15
13'	752	1117	1462	1853	2291	2771	3285	3843	4443	5086	5770	6497	7265	8076	8928	9803
	575	913	1363	1853	2291	2771	3285	3843	4443	5086	5770	6497	7265	8076	8928	9803
	1.5	1.5	3	3	4.5	4.5	6	6	7.5	9	9	10.5	12	12	13.5	15
14'	599	957	1258	1595	1971	2376	2818	3297	3812	4363	4951	5575	6235	6931	7662	8430
	460	731	1091	1554	1971	2376	2818	3297	3812	4363	4951	5575	6235	6931	7662	8430
	1.5	1.5	3	3	4.5	4.5	6	6	7.5	7.5	9	10.5	10.5	12	12	13.5
15'	484	775	1093	1386	1708	2059	2443	2858	3305	3783	4293	4834	5407	6010	6645	7311
	374	594	887	1263	1708	2059	2443	2858	3305	3783	4293	4834	5407	6010	6645	7311
	1.5	1.5	3	3	4.5	4.5	6	6	7.5	7.5	9	9	10.5	10.5	12	12
16'	396	635	955	1214	1493	1801	2136	2499	2891	3309	3756	4230	4731	5260	5815	6398
	308	490	731	1041	1428	1801	2136	2499	2891	3309	3756	4230	4731	5260	5815	6398
	1.5	1.5	3	3	4.5	4.5	6	6	7.5	7.5	9	9	10.5	10.5	12	12
17'	328	527	793	1069	1316	1587	1883	2204	2549	2918	3312	3730	4173	4639	5130	5644
	257	408	610	868	1191	1585	1883	2204	2549	2918	3312	3730	4173	4639	5130	5644
	1.5	1.5	3	3	4.5	4.5	6	6	7.5	7.5	9	9	10.5	10.5	12	12
18'	274	441	665	948	1167	1408	1671	1956	2263	2591	2942	3313	3706	4121	4557	5014
	217	344	514	731	1003	1335	1671	1956	2263	2591	2942	3313	3706	4121	4557	5014
	1.5	1.5	3	3	4.5	4.5	6	6	7.5	7.5	9	9	10.5	10.5	12	12
19'	231	372	562	806	1042	1258	1493	1748	2022	2316	2629	2961	3313	3684	4074	4483
	184	292	437	622	853	1135	1474	1748	2022	2316	2629	2961	3313	3684	4074	4483
	1.5	1.5	3	3	4.5	4.5	6	6	7.5	7.5	9	9	10.5	10.5	12	12
20'	195	317	479	688	936	1129	1341	1570	1817	2081	2362	2661	2978	3311	3662	4030
	158	251	374	533	731	973	1263	1570	1817	2081	2362	2661	2978	3311	3662	4030
	1.5	1.5	3	3	4.5	4.5	6	6	7.5	7.5	9	9	10.5	10.5	12	12
21'	167	271	411	591	817	1019	1210	1417	1640	1879	2134	2404	2690	2992	3309	3641
	136	217	323	460	632	841	1091	1388	1640	1879	2134	2404	2690	2992	3309	3641
	1.5	1.5	3	3	4.5	4.5	6	6	7.5	7.5	9	9	10.5	10.5	12	12
22'	143	234	355	511	707	924	1098	1285	1488	1705	1936	2181	2441	2715	3003	3305
	119	188	281	400	549	731	949	1207	1488	1705	1936	2181	2441	2715	3003	3305
	1.5	1.5	3	3	4.5	4.5	6	6	7.5	7.5	9	9	10.5	10.5	12	12
23'	123	202	308	445	616	825	999	1171	1355	1553	1764	1988	2225	2474	2737	3013
	104	165	246	350	481	640	831	1056	1319	1553	1764	1988	2225	2474	2737	3013
	1.5	1.5	3	3	4.5	4.5	6	6	7.5	7.5	9	9	10.5	10.5	12	12
24'	107	176	269	389	539	723	913	1070	1239	1420	1613	1818	2035	2264	2504	2757
	91	145	217	308	423	563	731	930	1161	1420	1613	1818	2035	2264	2504	2757
	1.5	1.5	3	3	4.5	4.5	6	6	7.5	7.5	9	9	10.5	10.5	12	12
25'	93	154	235	341	474	637	832	982	1137	1303	1480	1669	1868	2078	2299	2531
	81	128	192	273	374	498	647	822	1027	1263	1480	1669	1868	2078	2299	2531
	1.5	1.5	3	3	4.5	4.5	6	6	7.5	7.5	9	9	10.5	10.5	12	12
26'	81	135	207	301	419	563	737	903	1046	1199	1363	1536	1720	1914	2118	2332
	72	114	170	243	333	443	575	731	913	1123	1363	1536	1720	1914	2118	2332
	1.5	1.5	3	3	4.5	4.5	6	6	7.5	7.5	9	9	10.5	10.5	12	12
27'	71	118	183	266	371	500	655	834	966	1107	1258	1419	1589	1768	1956	2154
	64	102	152	217	297	396	514	653	815	1003	1217	1419	1589	1768	1956	2154
	1.5	1.5	3	3	4.5	4.5	6	6	7.5	7.5	9	9	10.5	10.5	12	12
28'	62	104	162	236	330	445	584	748	894	1025	1165	1314	1471	1637	1812	1996
	58	91	136	194	266	355	460	585	731	899	1091	1309	1471	1637	1812	1996
	1.5	1.5	3	3	4.5	4.5	6	6	7.5	7.5	9	9	10.5	10.5	12	12
29'	54	92	144	210	295	398	522	670	829	951	1081	1220	1366	1520	1683	1853
	52	82	123	175	240	319	414	527	658	809	982	1178	1366	1520	1683	1853
	1.5	1.5	3	3	4.5	4.5	6	6	7.5	7.5	9	9	10.5	10.5	12	12
30'	47	81	128	188	264	357	469	602	757	885	1006	1135	1271	1415	1567	1725
	47	74	111	158	217	288	374	476	594	731	887	1064	1263	1415	1567	1725
	1.5	1.5	3	3	4.5	4.5	6	6	7.5	7.5	9	9	10.5	10.5	12	12
32'	36	64	102	151	213	289	381	490	618	766	876	989	1108	1234	1366	1505
	36	61	91	130	179	238	308	392	490	602	731	877	1041	1224	1366	1505
	1.5	1.5	3	3	4.5	4.5	6	6	7.5	7.5	9	9	10.5	10.5	12	12

Allowable Roof Load Tables LDF=1.25

6-3/4" Widths - Standard Depths

Key - for each clear span there are three numbers:

- Row 1: Maximum Total Load with LDF of 1.25, and deflection limited to L/180
- Row 2: Maximum Live Load limited by deflection of L/240
- Row 3: Required Bearing Length in trimmer thickness (e.g., 1.5 = 1 trimmer, 3.0 = 2 trimmers, etc.)

These tables can be used to size simple span beams and headers that carry uniform loads. The PLF loads must be calculated and take into account all floor and roof framing loads coming onto the beam or header.

Allowable Loads for Anthony Glulam in Pounds per Linear Foot

Actual Span	6 3/4"															
	Depth (in.)															
	8 1/4	9 5/8	11	12 3/8	13 3/4	15 1/8	16 1/2	17 7/8	19 1/4	20 5/8	22	23 3/8	24 3/4	26 1/8	27 1/2	28 7/8
6'	4239	5772	7542	9524	11238	13177	15391	17941	20910	24410	28599	33701	38240	42609	47215	52058
	4239	5772	7542	9524	11238	13177	15391	17941	20910	24410	28599	33701	38240	42609	47215	52058
	3	4.5	6	7.5	7.5	9	10.5	13.5	15	18	22.5	27	31.5	36	40.5	46.5
7'	3110	4236	5536	7009	8656	10229	11762	13471	15386	17548	20007	22830	26104	29945	34514	38127
	3110	4236	5536	7009	8656	10229	11762	13471	15386	17548	20007	22830	26104	29945	34514	38127
	3	4.5	4.5	6	7.5	9	10.5	12	13.5	15	16.5	19.5	22.5	27	31.5	36
8'	2378	3239	4234	5361	6622	8015	9516	10781	12168	13693	15381	17257	19356	21718	24398	27463
	2378	3239	4234	5361	6622	8015	9516	10781	12168	13693	15381	17257	19356	21718	24398	27463
	3	3	4.5	4.5	6	7.5	9	10.5	12	13.5	15	16.5	19.5	21	24	28.5
9'	1876	2556	3341	4231	5227	6327	7532	8843	10061	11225	12489	13868	15376	17033	18862	20892
	1733	2556	3341	4231	5227	6327	7532	8843	10061	11225	12489	13868	15376	17033	18862	20892
	3	3	4.5	4.5	6	7.5	7.5	9	10.5	12	13.5	15	16.5	18	21	22.5
10'	1516	2067	2702	3423	4229	5120	6095	7156	8300	9498	10511	11589	12751	14008	15371	16855
	1263	2006	2702	3423	4229	5120	6095	7156	8300	9498	10511	11589	12751	14008	15371	16855
	3	3	3	4.5	4.5	6	7.5	9	9	10.5	12	13.5	15	16.5	18	19.5
11'	1251	1705	2230	2825	3490	4226	5032	5901	6821	7805	8855	9952	10890	11893	12968	14122
	949	1507	2230	2825	3490	4226	5032	5901	6821	7805	8855	9952	10890	11893	12968	14122
	1.5	3	3	4.5	4.5	6	6	7.5	9	10.5	12	12	13.5	15	16.5	18
12'	960	1430	1871	2370	2929	3547	4216	4931	5701	6524	7402	8333	9318	10331	11212	12150
	731	1161	1733	2370	2929	3547	4216	4931	5701	6524	7402	8333	9318	10331	11212	12150
	1.5	3	3	4.5	4.5	6	7.5	7.5	9	10.5	12	12	13.5	15	16.5	18
13'	752	1200	1591	2016	2492	3014	3574	4180	4833	5531	6275	7065	7901	8782	9708	10660
	575	913	1363	1941	2492	3014	3574	4180	4833	5531	6275	7065	7901	8782	9708	10660
	1.5	3	3	4.5	4.5	6	6	7.5	9	9	10.5	12	13.5	15	16.5	18
14'	599	957	1369	1735	2145	2585	3066	3586	4146	4746	5385	6064	6781	7537	8333	9167
	460	731	1091	1554	2132	2585	3066	3586	4146	4746	5385	6064	6781	7537	8333	9167
	1.5	1.5	3	3	4.5	4.5	6	7.5	7.5	9	9	10.5	12	13.5	15	15
15'	484	775	1163	1509	1858	2241	2658	3109	3595	4115	4670	5258	5881	6537	7227	7951
	374	594	887	1263	1733	2241	2658	3109	3595	4115	4670	5258	5881	6537	7227	7951
	1.5	1.5	3	3	4.5	4.5	6	6	7.5	7.5	9	10.5	10.5	12	13.5	15
16'	396	635	955	1321	1625	1960	2324	2720	3145	3601	4086	4601	5146	5721	6325	6959
	308	490	731	1041	1428	1901	2324	2720	3145	3601	4086	4601	5146	5721	6325	6959
	1.5	1.5	3	3	4.5	4.5	6	6	7.5	9	9	10.5	10.5	12	12	12
17'	328	527	793	1135	1432	1727	2049	2398	2773	3175	3604	4059	4540	5047	5580	6140
	257	408	610	868	1191	1585	2049	2398	2773	3175	3604	4059	4540	5047	5580	6140
	1.5	1.5	1.5	3	3	4.5	4.5	6	6	7.5	7.5	9	9	10.5	12	12
18'	274	441	665	952	1271	1533	1819	2129	2463	2820	3201	3605	4033	4484	4958	5455
	217	344	514	731	1003	1335	1733	2129	2463	2820	3201	3605	4033	4484	4958	5455
	1.5	1.5	1.5	3	3	4.5	4.5	6	6	7.5	9	9	10.5	10.5	12	12
19'	231	372	562	806	1112	1369	1625	1902	2201	2520	2861	3222	3605	4008	4432	4877
	184	292	437	622	853	1135	1474	1874	2201	2520	2861	3222	3605	4008	4432	4877
	1.5	1.5	1.5	3	3	4.5	4.5	6	6	7.5	7.5	9	9	10.5	10.5	12
20'	195	317	479	688	950	1230	1460	1709	1978	2265	2571	2896	3240	3603	3985	4385
	158	251	374	533	731	973	1263	1606	1978	2265	2571	2896	3240	3603	3985	4385
	1.5	1.5	1.5	3	3	4.5	4.5	6	6	7.5	7.5	9	9	10.5	10.5	12
21'	167	271	411	591	817	1093	1318	1543	1786	2046	2323	2617	2928	3256	3601	3963
	136	217	323	460	632	841	1091	1388	1733	2046	2323	2617	2928	3256	3601	3963
	1.5	1.5	1.5	3	3	4.5	4.5	6	6	7.5	7.5	9	9	10.5	10.5	12
22'	143	234	355	511	707	947	1196	1400	1620	1856	2108	2375	2657	2955	3269	3597
	119	188	281	400	549	731	949	1207	1507	1854	2108	2375	2657	2955	3269	3597
	1.5	1.5	1.5	3	3	4.5	4.5	6	6	7.5	7.5	9	9	10.5	10.5	12
23'	123	202	308	445	616	825	1077	1275	1476	1691	1921	2164	2422	2694	2980	3280
	104	165	246	350	481	640	831	1056	1319	1622	1921	2164	2422	2694	2980	3280
	1.5	1.5	1.5	3	3	4.5	4.5	6	6	7.5	7.5	9	9	10.5	10.5	12
24'	107	176	269	389	539	723	945	1166	1350	1547	1757	1980	2216	2465	2726	3001
	91	145	217	308	423	563	731	930	1161	1428	1733	1980	2216	2465	2726	3001
	1.5	1.5	1.5	3	3	4.5	4.5	6	6	7.5	7.5	9	9	10.5	10.5	12
25'	93	154	235	341	474	637	832	1064	1239	1420	1613	1817	2034	2263	2504	2756
	81	128	192	273	374	498	647	822	1027	1263	1533	1817	2034	2263	2504	2756
	1.5	1.5	1.5	3	3	4.5	4.5	6	6	7.5	7.5	9	9	10.5	10.5	12
26'	81	135	207	301	419	563	737	942	1140	1307	1485	1674	1874	2084	2306	2539
	72	114	170	243	333	443	575	731	913	1123	1363	1635	1874	2084	2306	2539
	1.5	1.5	1.5	3	3	4.5	4.5	6	6	7.5	7.5	9	9	10.5	10.5	12
27'	71	118	183	266	371	500	655	838	1052	1207	1371	1546	1731	1926	2131	2346
	64	102	152	217	297	396	514	653	815	1003	1217	1460	1731	1926	2131	2346
	1.5	1.5	1.5	3	3	4.5	4.5	6	6	7.5	7.5	9	9	10.5	10.5	12
28'	62	104	162	236	330	445	584	748	940	1118	1270	1432	1603	1784	1974	2174
	58	91	136	194	266	355	460	585	731	899	1091	1309	1554	1784	1974	2174
	1.5	1.5	1.5	3	3	4.5	4.5	6	6	7.5	7.5	9	9	10.5	10.5	12
29'	54	92	144	210	295	398	522	670	842	1037	1179	1329	1489	1657	1834	2019
	52	82	123	175	240	319	414	527	658	809	982	1178	1399	1645	1834	2019
	1.5	1.5	1.5	3	3	4.5	4.5	6	6	7.5	7.5	9	9	10.5	10.5	12
30'	47	81	128	188	264	357	469	602	757	937	1097	1237	1386	1542	1707	1880
	47	74	111	158	217	288	374	476	594	731	887	1064	1263	1486	1707	1880
	1.5	1.5	1.5	3	3	4.5	4.5	6	6	7.5	7.5	9	9	10.5	10.5	12
32'	36	64	102	151	213	289	381	490	618	766	935	1079	1208	1345	1489	1641
	36	61	91	130	179	238	308	392	490	602	731	877	1041	1224	1428	1641
	1.5	1.5	1.5	3	3	4.5	4.5	6	6	7.5	7.5	9	9	10.5	10.5	12

Allowable Floor Load Tables LDF=1.00 8-3/4" Widths - Standard Depths

Key - for each clear span there are three numbers:

- Row 1: Maximum Total Load with LDF of 1.0, and deflection limited to L/240
- Row 2: Maximum Live Load limited by deflection of L/360
- Row 3: Required Bearing Length in trimmer thickness (e.g., 1.5 = 1 trimmer, 3.0 = 2 trimmers, etc.)

These tables can be used to size simple span beams and headers that carry uniform loads. The PLF loads must be calculated and take into account all floor and roof framing loads coming onto the beam or header.

Allowable Loads for Anthony Glulam in Pounds per Linear Foot

Actual Span	8 3/4"															
	Depth (in.)															
	8 1/4	9 5/8	11	12 3/8	13 3/4	15 1/8	16 1/2	17 7/8	19 1/4	20 5/8	22	23 3/8	24 3/4	26 1/8	27 1/2	28 7/8
10'	1569	2139	2797	3544	4379	5296	6278	7342	8487	9712	10890	12007	13212	14514	15927	17465
	1092	1734	2588	3544	4379	5296	6278	7342	8487	9712	10890	12007	13212	14514	15927	17465
	1.5	3	3	3	4.5	4.5	6	6	7.5	9	10.5	10.5	12	13.5	15	16.5
11'	1211	1764	2307	2924	3609	4349	5157	6031	6972	7980	9053	10193	11281	12321	13435	14632
	820	1303	1944	2769	3609	4349	5157	6031	6972	7980	9053	10193	11281	12321	13435	14632
	1.5	3	3	3	4.5	4.5	6	6	7.5	7.5	9	10.5	10.5	12	13.5	15
12'	928	1478	1935	2451	3014	3633	4308	5039	5826	6668	7566	8518	9526	10589	11615	12586
	632	1003	1498	2132	2925	3633	4308	5039	5826	6668	7566	8518	9526	10589	11615	12586
	1.5	1.5	3	3	3	4.5	4.5	6	6	7.5	7.5	9	10.5	10.5	12	13.5
13'	726	1161	1645	2076	2553	3078	3650	4270	4937	5652	6413	7221	8076	8977	9924	10918
	497	789	1178	1677	2301	3062	3650	4270	4937	5652	6413	7221	8076	8977	9924	10918
	1.5	1.5	3	3	3	4.5	4.5	6	6	7.5	7.5	9	9	10.5	12	12
14'	577	925	1389	1779	2188	2639	3130	3662	4235	4848	5502	6195	6929	7703	8516	9370
	398	632	943	1343	1842	2452	3130	3662	4235	4848	5502	6195	6929	7703	8516	9370
	1.5	1.5	3	3	3	3	4.5	4.5	6	6	7.5	7.5	9	9	10.5	12
15'	466	748	1124	1541	1896	2286	2712	3174	3670	4202	4769	5371	6008	6679	7385	8125
	324	514	767	1092	1498	1993	2588	3174	3670	4202	4769	5371	6008	6679	7385	8125
	1.5	1.5	1.5	3	3	3	4.5	4.5	6	6	6	7.5	7.5	9	9	10.5
16'	380	612	922	1320	1657	1998	2371	2775	3210	3675	4172	4699	5256	5843	6461	7110
	267	423	632	900	1234	1643	2132	2711	3210	3675	4172	4699	5256	5843	6461	7110
	1.5	1.5	1.5	3	3	3	4.5	4.5	6	6	6	6	7.5	7.5	9	10.5
17'	314	507	764	1096	1459	1761	2090	2446	2829	3240	3678	4143	4635	5153	5699	6271
	222	353	527	750	1029	1369	1778	2260	2823	3240	3678	4143	4635	5153	5699	6271
	1.5	1.5	1.5	3	3	3	4.5	4.5	4.5	6	6	6	7.5	7.5	9	9
18'	261	423	640	918	1268	1562	1854	2171	2512	2877	3266	3679	4116	4577	5061	5570
	187	297	444	632	867	1154	1498	1904	2378	2877	3266	3679	4116	4577	5061	5570
	1.5	1.5	1.5	1.5	3	3	3	4.5	4.5	6	6	6	6	7.5	7.5	9
19'	219	356	540	777	1073	1394	1656	1939	2243	2570	2918	3287	3678	4090	4523	4978
	159	253	377	537	737	981	1273	1619	2022	2487	2918	3287	3678	4090	4523	4978
	1.5	1.5	1.5	1.5	3	3	3	3	4.5	4.5	4.5	6	6	7.5	7.5	9
20'	185	302	459	662	915	1226	1486	1741	2015	2308	2621	2953	3305	3676	4065	4475
	136	217	324	461	632	841	1092	1388	1734	2132	2588	2953	3305	3676	4065	4475
	1.5	1.5	1.5	1.5	1.5	3	3	3	4.5	4.5	6	6	6	6	7.5	7.5
21'	157	258	393	568	786	1054	1341	1571	1819	2084	2367	2667	2985	3320	3672	4042
	118	187	279	398	546	726	943	1199	1498	1842	2236	2667	2985	3320	3672	4042
	1.5	1.5	1.5	1.5	1.5	3	3	3	4.5	4.5	4.5	6	6	6	7.5	7.5
22'	134	221	339	490	679	912	1191	1424	1649	1890	2147	2419	2708	3012	3332	3668
	103	163	243	346	475	632	820	1043	1303	1602	1944	2332	2708	3012	3332	3668
	1.5	1.5	1.5	1.5	1.5	3	3	3	4.5	4.5	4.5	6	6	6	6	7.5
23'	115	191	293	425	591	794	1038	1297	1502	1721	1955	2204	2467	2744	3036	3343
	90	142	213	303	415	553	718	913	1140	1402	1702	2041	2423	2744	3036	3343
	1.5	1.5	1.5	1.5	1.5	1.5	3	3	3	4.5	4.5	4.5	6	6	6	7.5
24'	99	165	255	371	516	694	909	1163	1372	1573	1787	2015	2256	2510	2777	3058
	79	125	187	267	366	487	632	803	1003	1234	1498	1796	2132	2508	2777	3058
	1.5	1.5	1.5	1.5	1.5	1.5	3	3	3	4.5	4.5	4.5	6	6	6	6
25'	85	144	222	324	453	610	799	1024	1258	1443	1640	1849	2070	2304	2549	2807
	70	111	166	236	324	431	559	711	888	1092	1325	1589	1887	2219	2549	2807
	1.5	1.5	1.5	1.5	1.5	1.5	3	3	3	4.5	4.5	4.5	6	6	6	6
26'	74	125	195	285	399	538	706	905	1138	1328	1509	1702	1906	2121	2347	2585
	62	99	147	210	288	383	497	632	789	971	1178	1413	1677	1973	2301	2585
	1.5	1.5	1.5	1.5	1.5	1.5	1.5	3	3	3	4.5	4.5	4.5	4.5	6	6
27'	64	109	171	251	353	477	627	804	1011	1225	1393	1571	1759	1958	2168	2387
	55	88	131	187	257	342	444	564	705	867	1052	1262	1498	1761	2054	2378
	1.5	1.5	1.5	1.5	1.5	1.5	1.5	3	3	3	3	4.5	4.5	4.5	6	6
28'	55	96	151	222	313	424	558	716	902	1117	1289	1454	1629	1813	2007	2211
	50	79	118	168	230	306	398	506	632	777	943	1131	1343	1579	1842	2132
	1.5	1.5	1.5	1.5	1.5	1.5	1.5	3	3	3	3	4.5	4.5	4.5	4.5	6
29'	48	84	133	197	278	378	498	641	807	1000	1196	1349	1512	1683	1863	2053
	45	71	106	151	207	276	358	455	569	699	849	1018	1209	1422	1658	1919
	1.5	1.5	1.5	1.5	1.5	1.5	1.5	1.5	3	3	3	4.5	4.5	4.5	4.5	6
30'	41	74	118	175	248	338	446	575	725	899	1098	1255	1406	1566	1734	1910
	40	64	96	136	187	249	324	411	514	632	767	920	1092	1284	1498	1734
	1.5	1.5	1.5	1.5	1.5	1.5	1.5	1.5	3	3	3	3	4.5	4.5	4.5	4.5
32'	30	57	92	139	199	272	361	466	589	732	896	1081	1225	1364	1511	1665
	30	53	79	112	154	205	267	339	423	521	632	758	900	1058	1234	1429
	1.5	1.5	1.5	1.5	1.5	1.5	1.5	1.5	1.5	3	3	3	4.5	4.5	4.5	4.5
34'	22	43	73	111	160	221	294	381	484	602	738	892	1066	1197	1327	1462
	22	43	66	94	129	171	222	283	353	434	527	632	750	882	1029	1191
	1.5	1.5	1.5	1.5	1.5	1.5	1.5	1.5	1.5	3	3	3	3	4.5	4.5	4.5
36'	16	33	57	89	130	180	242	315	400	500	614	743	889	1053	1173	1293
	16	33	55	79	108	144	187	238	297	366	444	532	632	743	867	1003
	1.5	1.5	1.5	1.5	1.5	1.5	1.5	1.5	1.5	3	3	3	3	4.5	4.5	4.5
38'	10	25	45	71	106	148	200	261	334	417	514	623	747	886	1040	1150
	10	25	45	67	92	123	159	202	253	311	377	453	537	632	737	853
	1.5	1.5	1.5	1.5	1.5	1.5	1.5	1.5	1.5	1.5	3	3	3	3	4.5	4.5
40'	6	18	35	57	86	122	166	218	279	351	433	527	632	751	883	1029
	6	18	35	57	79	105	136	174	217	267	324	388	461	542	632	731
	1.5	1.5	1.5	1.5	1.5	1.5	1.5	1.5	1.5	1.5	1.5	3	3	3	3	4.5

Allowable Roof Load Tables LDF=1.15

8-3/4" Widths - Standard Depths

Key - for each clear span there are three numbers:

- Row 1: Maximum Total Load with LDF of 1.15, and deflection limited to L/180
- Row 2: Maximum Live Load limited by deflection of L/240
- Row 3: Required Bearing Length in trimmer thickness (e.g., 1.5 = 1 trimmer, 3.0 = 2 trimmers, etc.)

These tables can be used to size simple span beams and headers that carry uniform loads. The PLF loads must be calculated and take into account all floor and roof framing loads coming onto the beam or header.

Allowable Loads for Anthony Glulam in Pounds per Linear Foot

Actual Span	8 3/4"															
	Depth (in.)															
	8 1/4	9 5/8	11	12 3/8	13 3/4	15 1/8	16 1/2	17 7/8	19 1/4	20 5/8	22	23 3/8	24 3/4	26 1/8	27 1/2	28 7/8
10'	1807	2463	3221	4080	5041	6095	7226	8450	9767	11176	12531	13816	15202	16701	18326	20095
	1638	2463	3221	4080	5041	6095	7226	8450	9767	11176	12531	13816	15202	16701	18326	20095
	1.5	3	3	4.5	4.5	6	6	7.5	9	10.5	10.5	12	13.5	15	16.5	18
11'	1490	2032	2657	3367	4155	5007	5936	6942	8025	9184	10419	11730	12982	14178	15460	16837
	1230	1954	2657	3367	4155	5007	5936	6942	8025	9184	10419	11730	12982	14178	15460	16837
	1.5	3	3	3	4.5	4.5	6	7.5	7.5	9	10.5	12	12	13.5	15	16.5
12'	1244	1703	2229	2823	3471	4183	4960	5801	6707	7676	8708	9805	10964	12186	13367	14485
	948	1505	2229	2823	3471	4183	4960	5801	6707	7676	8708	9805	10964	12186	13367	14485
	1.5	3	3	3	4.5	4.5	6	6	7.5	7.5	9	10.5	12	13.5	13.5	15
13'	974	1448	1895	2392	2941	3545	4204	4917	5685	6507	7383	8312	9296	10333	11423	12566
	745	1184	1767	2392	2941	3545	4204	4917	5685	6507	7383	8312	9296	10333	11423	12566
	1.5	1.5	3	3	4.5	4.5	4.5	6	6	7.5	9	9	10.5	12	13.5	15
14'	776	1241	1627	2051	2522	3040	3606	4218	4877	5583	6335	7133	7977	8868	9804	10785
	597	948	1415	2014	2522	3040	3606	4218	4877	5583	6335	7133	7977	8868	9804	10785
	1.5	1.5	3	3	3	4.5	4.5	6	6	7.5	7.5	9	10.5	10.5	12	13.5
15'	627	1005	1409	1776	2185	2634	3125	3656	4228	4840	5492	6185	6917	7690	8502	9354
	485	771	1150	1638	2185	2634	3125	3656	4228	4840	5492	6185	6917	7690	8502	9354
	1.5	1.5	3	3	3	4.5	4.5	4.5	6	6	7.5	7.5	9	10.5	10.5	12
16'	514	824	1231	1552	1910	2303	2733	3198	3698	4234	4805	5412	6053	6729	7440	8186
	400	635	948	1349	1851	2303	2733	3198	3698	4234	4805	5412	6053	6729	7440	8186
	1.5	1.5	3	3	3	4.5	4.5	6	6	7.5	7.5	9	9	10.5	10.5	12
17'	425	683	1027	1368	1683	2030	2409	2819	3261	3734	4238	4773	5339	5936	6563	7222
	333	529	790	1125	1543	2030	2409	2819	3261	3734	4238	4773	5339	5936	6563	7222
	1.5	1.5	1.5	3	3	3	4.5	4.5	4.5	6	6	7.5	7.5	9	9	10.5
18'	355	572	861	1213	1493	1802	2138	2503	2895	3315	3763	4239	4742	5272	5830	6416
	281	446	666	948	1300	1730	2138	2503	2895	3315	3763	4239	4742	5272	5830	6416
	1.5	1.5	1.5	3	3	3	4.5	4.5	4.5	6	6	7.5	7.5	9	9	10.5
19'	299	483	729	1045	1333	1609	1910	2236	2587	2962	3363	3788	4238	4713	5212	5735
	239	379	566	806	1105	1471	1910	2236	2587	2962	3363	3788	4238	4713	5212	5735
	1.5	1.5	1.5	3	3	3	4.5	4.5	4.5	6	6	7.5	7.5	9	9	9
20'	253	411	621	892	1197	1445	1715	2008	2324	2662	3022	3405	3809	4236	4685	5156
	205	325	485	691	948	1261	1638	2008	2324	2662	3022	3405	3809	4236	4685	5156
	1.5	1.5	1.5	1.5	3	3	4.5	4.5	4.5	6	6	7.5	7.5	9	9	9
21'	216	352	533	766	1059	1304	1548	1813	2098	2404	2730	3075	3441	3827	4233	4659
	177	281	419	597	819	1090	1415	1799	2098	2404	2730	3075	3441	3827	4233	4659
	1.5	1.5	1.5	1.5	3	3	3	4.5	4.5	6	6	6	7.5	7.5	9	9
22'	186	303	460	663	917	1182	1404	1644	1903	2181	2477	2791	3123	3473	3842	4229
	154	244	365	519	712	948	1230	1564	1903	2181	2477	2791	3123	3473	3842	4229
	1.5	1.5	1.5	1.5	3	3	3	4.5	4.5	6	6	6	7.5	7.5	9	9
23'	160	262	399	576	798	1070	1278	1497	1734	1987	2256	2543	2846	3165	3502	3854
	135	214	319	454	623	829	1077	1369	1710	1987	2256	2543	2846	3165	3502	3854
	1.5	1.5	1.5	1.5	3	3	3	4.5	4.5	6	6	6	7.5	7.5	9	9
24'	138	228	348	504	699	938	1168	1369	1585	1816	2063	2326	2603	2896	3204	3527
	118	188	281	400	548	730	948	1205	1505	1816	2063	2326	2603	2896	3204	3527
	1.5	1.5	1.5	1.5	3	3	3	4.5	4.5	6	6	6	7.5	7.5	9	9
25'	120	199	305	442	614	825	1071	1256	1454	1667	1894	2134	2389	2658	2941	3238
	105	166	248	354	485	646	839	1066	1332	1638	1894	2134	2389	2658	2941	3238
	1.5	1.5	1.5	1.5	3	3	3	4.5	4.5	6	6	6	7.5	7.5	9	9
26'	105	174	268	390	543	730	955	1155	1338	1534	1743	1965	2200	2448	2709	2983
	93	148	221	314	431	574	745	948	1184	1456	1743	1965	2200	2448	2709	2983
	1.5	1.5	1.5	1.5	3	3	3	4.5	4.5	6	6	6	7.5	7.5	9	9
27'	91	153	237	345	481	648	848	1066	1235	1416	1610	1815	2032	2261	2502	2755
	83	132	197	281	385	513	666	846	1057	1300	1578	1815	2032	2261	2502	2755
	1.5	1.5	1.5	1.5	3	3	3	4.5	4.5	6	6	6	7.5	7.5	9	9
28'	80	135	210	306	428	577	757	969	1143	1311	1490	1680	1882	2094	2318	2553
	75	118	177	252	345	460	597	759	948	1166	1415	1680	1882	2094	2318	2553
	1.5	1.5	1.5	1.5	3	3	3	4.5	4.5	6	6	6	7.5	7.5	9	9
29'	70	119	186	273	382	516	677	868	1061	1217	1383	1560	1747	1945	2153	2371
	67	107	159	227	311	414	537	683	853	1049	1273	1527	1747	1945	2153	2371
	1.5	1.5	1.5	1.5	3	3	3	4.5	4.5	6	6	6	7.5	7.5	9	9
30'	61	106	166	244	342	463	608	780	982	1132	1287	1452	1626	1810	2004	2207
	61	96	144	205	281	374	485	617	771	948	1150	1380	1626	1810	2004	2207
	1.5	1.5	1.5	1.5	3	3	3	4.5	4.5	6	6	6	7.5	7.5	9	9
32'	47	83	132	196	276	375	494	635	801	985	1121	1265	1417	1578	1747	1925
	47	79	118	169	231	308	400	508	635	781	948	1137	1349	1578	1747	1925
	1.5	1.5	1.5	1.5	3	3	3	4.5	4.5	6	6	6	7.5	7.5	9	9
34'	36	65	106	158	225	307	405	523	660	819	984	1111	1245	1386	1535	1692
	36	65	99	141	193	257	333	424	529	651	790	948	1125	1323	1535	1692
	1.5	1.5	1.5	1.5	3	3	3	4.5	4.5	6	6	6	7.5	7.5	9	9
36'	27	52	85	129	184	253	335	434	549	682	835	982	1101	1226	1358	1497
	27	52	83	118	163	216	281	357	446	548	666	798	948	1115	1300	1497
	1.5	1.5	1.5	1.5	3	3	3	4.5	4.5	6	6	6	7.5	7.5	9	9
38'	20	40	68	105	152	209	279	362	460	573	703	850	979	1091	1209	1333
	20	40	68	101	138	184	239	304	379	466	566	679	806	948	1105	1280
	1.5	1.5	1.5	1.5	3	3	3	4.5	4.5	6	6	6	7.5	7.5	9	9
40'	15	31	55	86	125	174	234	305	388	484	595	721	863	976	1082	1193
	15	31	55	86	118	158	205	260	325	400	485	582	691	813	948	1097
	1.5	1.5	1.5	1.5	3	3	3	4.5	4.5	6	6	6	7.5	7.5	9	9

Allowable Roof Load Tables LDF=1.25

8-3/4" Widths - Standard Depths

Key - for each clear span there are three numbers:

- Row 1: Maximum Total Load with LDF of 1.25, and deflection limited to L/180
- Row 2: Maximum Live Load limited by deflection of L/240
- Row 3: Required Bearing Length in trimmer thickness (e.g., 1.5 = 1 trimmer, 3.0 = 2 trimmers, etc.)

These tables can be used to size simple span beams and headers that carry uniform loads. The PLF loads must be calculated and take into account all floor and roof framing loads coming onto the beam or header.

Allowable Loads for Anthony Glulam in Pounds per Linear Foot

Actual Span	8 3/4"															
	Depth (in.)															
	8 1/4	9 5/8	11	12 3/8	13 3/4	15 1/8	16 1/2	17 7/8	19 1/4	20 5/8	22	23 3/8	24 3/4	26 1/8	27 1/2	28 7/8
10'	1966	2679	3503	4437	5482	6628	7857	9188	10620	12153	13625	15023	16529	18158	19925	21849
	1638	2601	3503	4437	5482	6628	7857	9188	10620	12153	13625	15023	16529	18158	19925	21849
	3	3	3	4.5	4.5	6	7.5	9	9	10.5	12	13.5	15	16.5	18	19.5
11'	1621	2210	2891	3662	4519	5446	6456	7550	8727	9987	11330	12755	14116	15417	16810	18307
	1230	1954	2891	3662	4519	5446	6456	7550	8727	9987	11330	12755	14116	15417	16810	18307
	1.5	3	3	4.5	4.5	6	6	7.5	9	10.5	10.5	12	13.5	15	16.5	18
12'	1244	1854	2425	3072	3776	4550	5395	6309	7294	8347	9470	10662	11922	13251	14535	15750
	948	1505	2247	3072	3776	4550	5395	6309	7294	8347	9470	10662	11922	13251	14535	15750
	1.5	3	3	3	4.5	4.5	6	7.5	7.5	9	10.5	12	12	13.5	15	16.5
13'	974	1556	2062	2602	3199	3856	4572	5348	6183	7077	8029	9040	10109	11236	12422	13665
	745	1184	1767	2516	3199	3856	4572	5348	6183	7077	8029	9040	10109	11236	12422	13665
	1.5	3	3	3	4.5	4.5	6	6	7.5	7.5	9	10.5	12	13.5	15	15
14'	776	1241	1771	2231	2744	3308	3923	4588	5305	6072	6890	7758	8676	9644	10662	11729
	597	948	1415	2014	2744	3308	3923	4588	5305	6072	6890	7758	8676	9644	10662	11729
	1.5	1.5	3	3	4.5	4.5	6	6	6	7.5	9	9	10.5	12	13.5	15
15'	627	1005	1508	1933	2378	2867	3400	3978	4599	5265	5975	6728	7524	8364	9247	10173
	485	771	1150	1638	2247	2867	3400	3978	4599	5265	5975	6728	7524	8364	9247	10173
	1.5	1.5	3	3	3	4.5	4.5	6	6	7.5	7.5	9	10.5	10.5	12	13.5
16'	514	824	1238	1690	2079	2507	2974	3480	4024	4607	5228	5887	6584	7320	8093	8904
	400	635	948	1349	1851	2464	2974	3480	4024	4607	5228	5887	6584	7320	8093	8904
	1.5	1.5	3	3	3	4.5	4.5	6	6	7.5	9	9	10.5	12	12	12
17'	425	683	1027	1471	1832	2210	2622	3068	3548	4063	4611	5193	5808	6457	7140	7855
	333	529	790	1125	1543	2054	2622	3068	3548	4063	4611	5193	5808	6457	7140	7855
	1.5	1.5	1.5	3	3	3	4.5	4.5	6	6	7.5	7.5	9	9	10.5	12
18'	355	572	861	1234	1626	1961	2328	2724	3151	3608	4095	4612	5159	5736	6343	6979
	281	446	666	948	1300	1730	2247	2724	3151	3608	4095	4612	5159	5736	6343	6979
	1.5	1.5	1.5	3	3	3	4.5	4.5	4.5	6	6	7.5	7.5	9	10.5	10.5
19'	299	483	729	1045	1441	1752	2079	2434	2816	3224	3660	4123	4612	5128	5671	6240
	239	379	566	806	1105	1471	1910	2429	2816	3224	3660	4123	4612	5128	5671	6240
	1.5	1.5	1.5	3	3	3	4.5	4.5	4.5	6	6	7.5	7.5	9	9	10.5
20'	253	411	621	892	1231	1573	1868	2187	2530	2898	3289	3706	4146	4610	5098	5610
	205	325	485	691	948	1261	1638	2082	2530	2898	3289	3706	4146	4610	5098	5610
	1.5	1.5	1.5	1.5	3	3	4.5	4.5	6	6	6	7.5	7.5	9	9	9
21'	216	352	533	766	1059	1417	1686	1974	2285	2617	2971	3348	3746	4165	4607	5070
	177	281	419	597	819	1090	1415	1799	2247	2617	2971	3348	3746	4165	4607	5070
	1.5	1.5	1.5	1.5	3	3	4.5	4.5	4.5	6	6	7.5	7.5	9	9	9
22'	186	303	460	663	917	1228	1529	1791	2073	2375	2696	3038	3400	3781	4182	4602
	154	244	365	519	712	948	1230	1564	1954	2375	2696	3038	3400	3781	4182	4602
	1.5	1.5	1.5	1.5	3	3	4.5	4.5	4.5	6	6	6	7.5	7.5	9	9
23'	160	262	399	576	798	1070	1393	1631	1888	2164	2457	2769	3098	3446	3812	4196
	135	214	319	454	623	829	1077	1369	1710	2103	2457	2769	3098	3446	3812	4196
	1.5	1.5	1.5	1.5	3	3	4.5	4.5	4.5	6	6	6	7.5	7.5	9	9
24'	138	228	348	504	699	938	1225	1492	1727	1979	2247	2533	2835	3153	3488	3839
	118	188	281	400	548	730	948	1205	1505	1851	2247	2533	2835	3153	3488	3839
	1.5	1.5	1.5	1.5	3	3	4.5	4.5	4.5	6	6	6	6	7.5	7.5	9
25'	120	199	305	442	614	825	1079	1368	1584	1816	2063	2325	2602	2895	3203	3526
	105	166	248	354	485	646	839	1066	1332	1638	1988	2325	2602	2895	3203	3526
	1.5	1.5	1.5	1.5	3	3	4.5	4.5	4.5	6	6	6	6	7.5	7.5	9
26'	105	174	268	390	543	730	955	1221	1459	1672	1899	2141	2397	2666	2950	3248
	93	148	221	314	431	574	745	948	1184	1456	1767	2119	2397	2666	2950	3248
	1.5	1.5	1.5	1.5	3	3	4.5	4.5	4.5	6	6	6	6	7.5	7.5	9
27'	91	153	237	345	481	648	848	1086	1347	1544	1754	1977	2214	2463	2726	3001
	83	132	197	281	385	513	666	846	1057	1300	1578	1893	2214	2463	2726	3001
	1.5	1.5	1.5	1.5	3	3	4.5	4.5	4.5	6	6	6	6	6	7.5	7.5
28'	80	135	210	306	428	577	757	969	1218	1429	1624	1831	2051	2282	2525	2781
	75	118	177	252	345	460	597	759	948	1166	1415	1697	2014	2282	2525	2781
	1.5	1.5	1.5	1.5	3	3	4.5	4.5	4.5	6	6	6	6	6	7.5	7.5
29'	70	119	186	273	382	516	677	868	1092	1327	1508	1700	1904	2119	2345	2583
	67	107	159	227	311	414	537	683	853	1049	1273	1527	1813	2119	2345	2583
	1.5	1.5	1.5	1.5	3	3	4.5	4.5	4.5	6	6	6	6	6	6	6
30'	61	106	166	244	342	463	608	780	982	1215	1403	1583	1772	1973	2184	2405
	61	96	144	205	281	374	485	617	771	948	1150	1380	1638	1926	2184	2405
	1.5	1.5	1.5	1.5	3	3	4.5	4.5	4.5	6	6	6	6	6	6	6
32'	47	83	132	196	276	375	494	635	801	992	1212	1380	1546	1721	1905	2098
	47	79	118	169	231	308	400	508	635	781	948	1137	1349	1587	1851	2098
	1.5	1.5	1.5	1.5	3	3	4.5	4.5	4.5	6	6	6	6	6	6	6
34'	36	65	106	158	225	307	405	523	660	819	1001	1208	1358	1512	1675	1845
	36	65	99	141	193	257	333	424	529	651	790	948	1125	1323	1543	1787
	1.5	1.5	1.5	1.5	3	3	4.5	4.5	4.5	6	6	6	6	6	6	6
36'	27	52	85	129	184	253	335	434	549	682	835	1009	1201	1338	1482	1633
	27	52	83	118	163	216	281	357	446	548	666	798	948	1115	1300	1505
	1.5	1.5	1.5	1.5	3	3	4.5	4.5	4.5	6	6	6	6	6	6	6
38'	20	40	68	105	152	209	279	362	460	573	703	850	1016	1191	1320	1455
	20	40	68	101	138	184	239	304	379	466	566	679	806	948	1105	1280
	1.5	1.5	1.5	1.5	3	3	4.5	4.5	4.5	6	6	6	6	6	6	6
40'	15	31	55	86	125	174	234	305	388	484	595	721	863	1022	1182	1303
	15	31	55	86	118	158	205	260	325	400	485	582	691	813	948	1097
	1.5	1.5	1.5	1.5	3	3	4.5	4.5	4.5	6	6	6	6	6	6	6

Load Table Notations and Examples

Anthony Glulam Floor and Roof PLF Load Notes

1. Values shown are the maximum uniform loads in pounds per linear foot (PLF) that can be applied to the beam. Beam weight has been subtracted from the total allowable load. Load tables are based on dry use conditions.
2. LDF = Load Duration Factor per code requirements.
3. Bearing length shown is required at each end of header, and is based on an allowable bearing stress of 740 psi. The beam must be sitting directly on top of 1 or more trimmers. A longer bearing length may be required depending on the material that the beam is bearing on. For example, if the beam is sitting on a SPF top plate, a longer bearing length will be required due to the lower compression perpendicular-to-grain design value for SPF.
4. The bearing lengths show the number of trimmers needed (e.g., 1.5 = 1 trimmer, 3.0 = 2 trimmers, etc.). This is based on the maximum PLF loads. Shorter bearing lengths may be used with lighter loads.
5. Tables are based on simple span conditions using the actual span as the center-to-center of bearing. Tables do not apply for continuous or multiple span conditions. The clear opening for the actual span given can be found by subtracting the listed bearing length from the actual span.
6. The beam is assumed to be loaded on the top edge and supported at bearing points. The beams should be laterally braced.
7. For deflection limits of L/240 and L/480, multiply The Maximum Live Load figure (Row 2) by 1.5 and 0.75, respectively. For deflection factors of L/180 and L/360, multiply the Maximum Live Load figure (row 2) by 1.333 and 0.667, respectively. The result shall not exceed the total load.

Procedures for Using Simple Span Beam Tables

1. To size beams from the Floor and Roof PLF Tables it is required to have the following:
 - a. Live load determined by the governing Building Code (BOCA, ICBO, SBCCI, etc.)
 - b. The dead load.
 - c. The beam span or clear opening.
 - d. Span carried or tributary width.
2. These tables may be used to size a simple span uniformly distributed loaded beam, or to determine the maximum load capacity of a specific size Glulam beam. The allowable loads shown in PLF tables include the beam weight. A simple span condition exist when the beam is supported on each end without overhangs. A continuous or cantilever loading application may require a balanced layup and an engineering or design review.

Garage Door Header: Single Story Example Problem

Determine the header size for the conditions below:

Roof Load Conditions: Live (LL) = 30 psf
Dead (DL) = 10 psf

Building Width (B) = 24'

Overhang = 2'

Header Actual Span (L) = 17'

Formula:

Total Load = $(B/2+2') \times (LL + DL)$ = total applied load in PLF

Live Load = $(B/2+2') \times LL$ = total live load in PLF

Example:

Total Load = $(24/2 + 2) \times (30 + 10) = 560$ PLF

Live Load = $(24/2 + 2) \times 30 = 420$ PLF

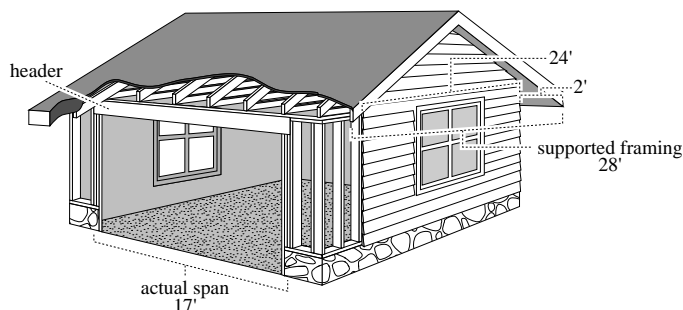

To size:

1. Go to allowable roof load tables (dependent upon width). LDF = 1.15 and find the 17' actual span row.
2. Using the top row, find a total load greater than 560 PLF (3-1/8 x 13-3/4, 3-1/2 x 12-3/8)
3. Using the middle row, find a live load greater than 420 PLF but also a total load greater than 560 PLF. (3-1/8 x 13 3/4 or 3-1/2 x 12-3/8).

Beam to select: 3-1/2 x 12-3/8 - 17' 3" or 18' (bearing required = 3")

Note:

If attic loading is anticipated, additional floor loading must be considered. Example: Add Floor LL=25, DL=10
Revised Total Load = 980 PLF, Live Load = 720 PLF (5-1/8 x 15-1/8 or 3-1/2 x 17-7/8 Required)

Load Table Examples

Anthony Glulam Sizing Examples

Garage or Window Header: Two Story Example Problem

Determine the header size for the conditions below:

Roof Load Conditions:	Live (LL)	= 30 psf
	Dead (DL)	= 15 psf
	Total	= 45 psf
Floor Load Conditions:	Live (LL)	= 40 psf
	Dead (DL)	= 10 psf
	Total	= 50 psf

Calculate Total Load:

Roof Load	=	$(28/2 + 2) \times 45$	=	720 PLF
Floor Load	=	$(14/2) \times 50$	=	350 PLF
Wall Load	=	$8' \times 10 \text{ psf}$	=	80 PLF
Total Load			=	1150 PLF

Calculate Live Load :

Roof Load	=	$(28/2 + 2) \times 30$	=	480 PLF
Floor Load	=	$(14/2) \times 40$	=	280 PLF
Live Load			=	760 PLF

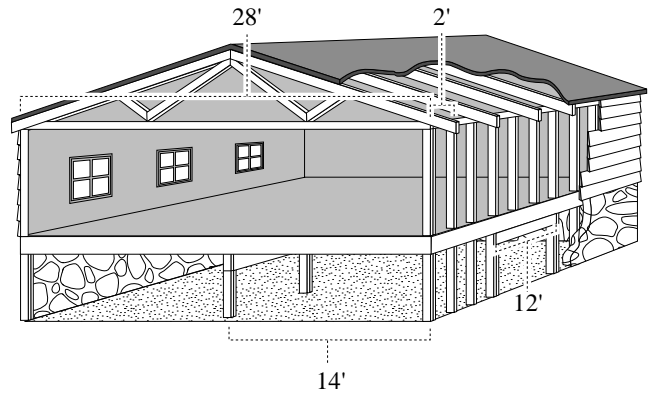

To Size:

1. Go to Floor Load Table using LDF = 1.00 and 12' actual span row.
2. Using top row, find total load equal to or greater than 1150 PLF. 3-1/8 x 15-1/8 or 3-1/2 x 13-3/4.
3. Using middle row, find live load equal to or greater than 760 PLF and a Total Load equal to or greater than 1200 PLF 3-1/8 x 15-1/8 or 3-1/2 x 13-3/4.

Beam to Select: 3-1/2 x 13-3/4 (3" bearing required) or 3-1/8 x 15 1/8 (4-1/2" Bearing required)

Floor Girder Beam Example Problem

Floor Load Conditions:	Live (LL)	= 40 psf
	Dead (DL)	= 12 psf
Building Width (B)		= 24'

Calculate Total Load:

$$\text{Total Load} = (24/2) \times (40 + 12) = 624 \text{ plf}$$

Calculate Live Load:

$$\text{Live Load} = (24/2) \times 40 = 480 \text{ plf}$$

Beam to Select (Floor Load Table):

5-1/8 x 15-1/8 - 20'3" or 21' (Bearing Required 3")

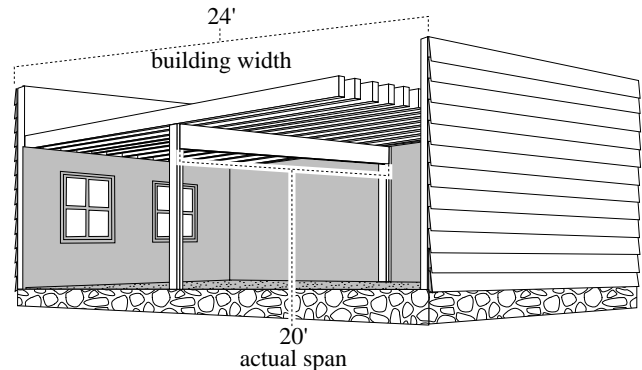

Simple Roof Rafter Example Problem

Determine the rafter size for the conditions below:

Roof Load Conditions:	Live (snow)	= 25 psf
	Dead	= 15 psf
Rafter Spacing:		5' on center
Rafter Span:		20'
Slope:		4/12

Calculate Total Load:

$$\text{Total Load} = 5(25 + 15) = 200 \text{ plf}$$

$$\text{Live Load} = 5(25) = 125 \text{ plf}$$

Beam to Select (Roof 1.15 Table):

3-1/8 or 3-1/2 x 11 (Bearing Required 1.5")

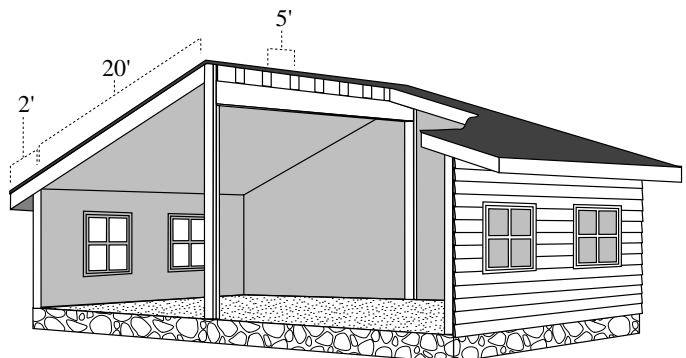

Note: If roof is greater than 4/12 pitch, dead load must be figured on total horizontal length of rafter.

Connection Details

Common types of connectors and connection details are shown. The design values for most fasteners used with the Glulam are the same as those for solid timber and LVL. It must be noted that connections designed for specific applications may vary based on design loads and local code requirements. More information on connections can be found in AITC 104, "Typical Construction Details," published by the American Institute of Timber Construction. Your local Glulam dealer can also provide connection detail literature and hardware.

Typical Hangers

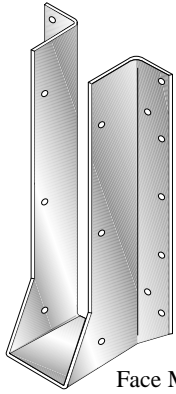

Face Mount Hanger

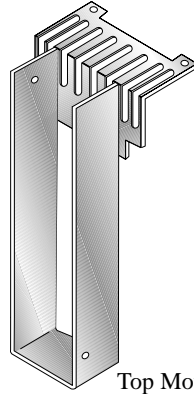

Top Mount Hanger

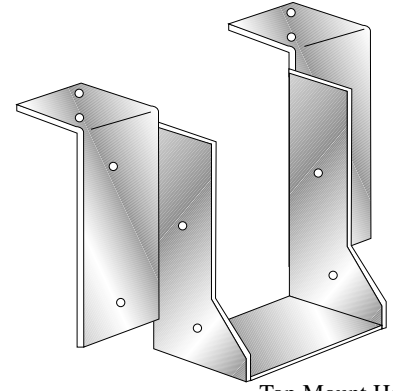

Top Mount Hanger

Typical Connections

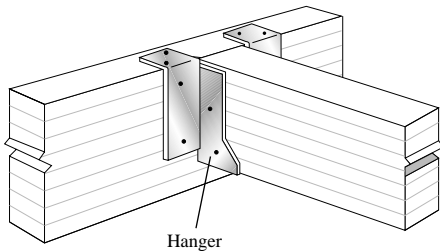

Hanger

Beam to Beam

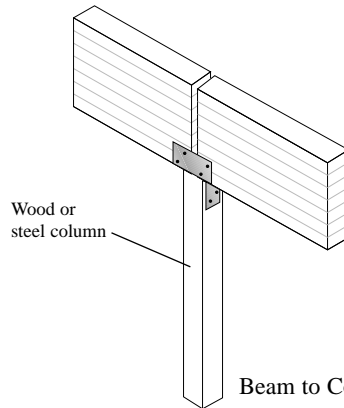

Wood or steel column

Beam to Column

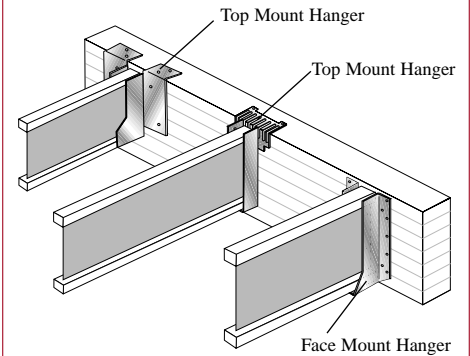

Top Mount Hanger

Top Mount Hanger

Face Mount Hanger

Floor Beam to Joist

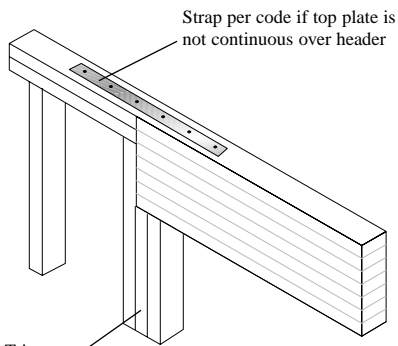

Strap per code if top plate is not continuous over header

Trimmers

Header to Frame

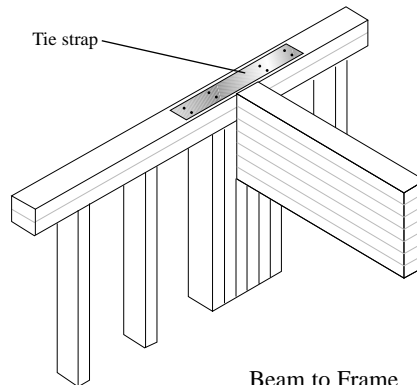

Tie strap

Beam to Frame

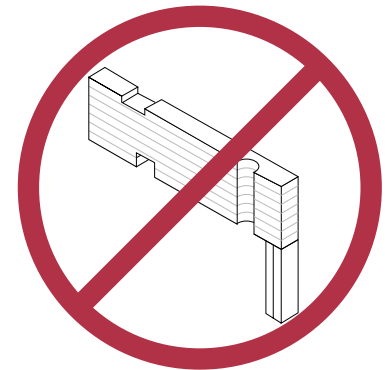

Do not cut or drill Anthony Glulams without tech note support

Guidelines for Drilling Horizontal Holes

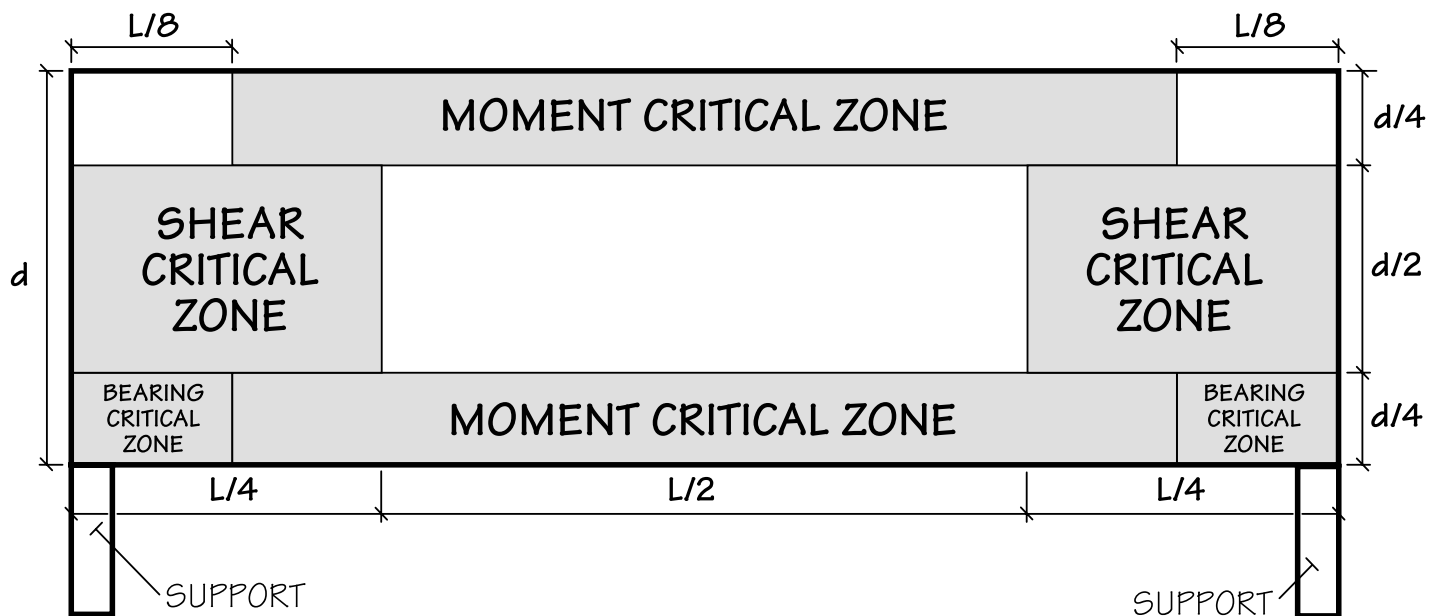

DO NOT DRILL IN CRITICAL ZONES

UNIFORMLY LOADED SINGLE SPAN BEAM GLUED LAMINATED TIMBER

Notes:

- 1. The maximum size horizontal hole** (through the width of the beam) shall not exceed 1-1/2 inch.
- 2. Edge and End Spacing:** Any horizontal hole must be a minimum of 4 hole diameters from the top or bottom surface of the glued laminated timber member, and 8 hole diameters from the member ends. The distance is measured from the edge of the member to the centerline of the hole.
- 3. Spacing between holes:** Field added open or access holes not shown on the contract drawings shall be a minimum of 8 hole diameters from any hole in the member. The distance is measured from the edge of the hole to the nearest edge of the existing hole.
- 4. Number of holes:** Determine the number of field added holes allowed by allowing one hole per each 5 foot length of the member. (This rule does not apply to spacing of holes.)
- 5. Other holes:** Holes not described here require review by a qualified timber designer.

L = length of beam
d = depth of beam

Vertical 1/2" Diameter Holes in Glulam Beams

While field-drilling vertical holes in Glulam beams should be avoided, there are situations where they may be required. This Technical Note provides guidance on the drilling of a single 1/2" vertical hole in simple span Glulam beams of various thicknesses. These recommendations are based on a "worst case" scenario that assumes the beam is placed at its maximum span and is fully loaded with uniformly distributed loads. Concentrated or other non-uniform loads have not been considered and for such loads or other situations the effect of drilling a vertical hole should be checked by a qualified design professional.

Background:

In analyzing a beam for the effect of drilling a single vertical hole it is necessary to consider both shear and bending capacities. Since the shear design requirements are greatest at the ends of the beam, vertical holes generally cannot be placed at these locations without analysis by a qualified design professional. In a similar manner, the center of the span is the area of maximum bending stress, and again, a design professional's analysis is required when holes are desired to be placed in these areas. Between the areas of high shear and high bending stress, small vertical holes can be placed. This Technical Note provides guidance on the location of these safe areas for drilling vertical holes 1/2 inch or less in diameter.

Drilling the hole:

These holes must be carefully drilled along the vertical axis of the beam. (see **Figure 1**.) If the beam is deep it is recommended to use a drill guide and a sharp bit to preclude the bit from wandering as it passes through the beam depth. In addition, the beam should be inspected at the possible hole location to insure that there are no knots, Knot-holes, finger joints or other allowable defects in the vicinity of the hole (within the width of the beam on either side of the hole).

Figure 1: Hole in Glulam Beam

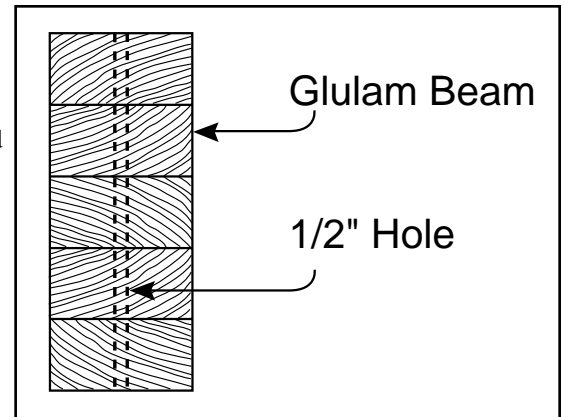
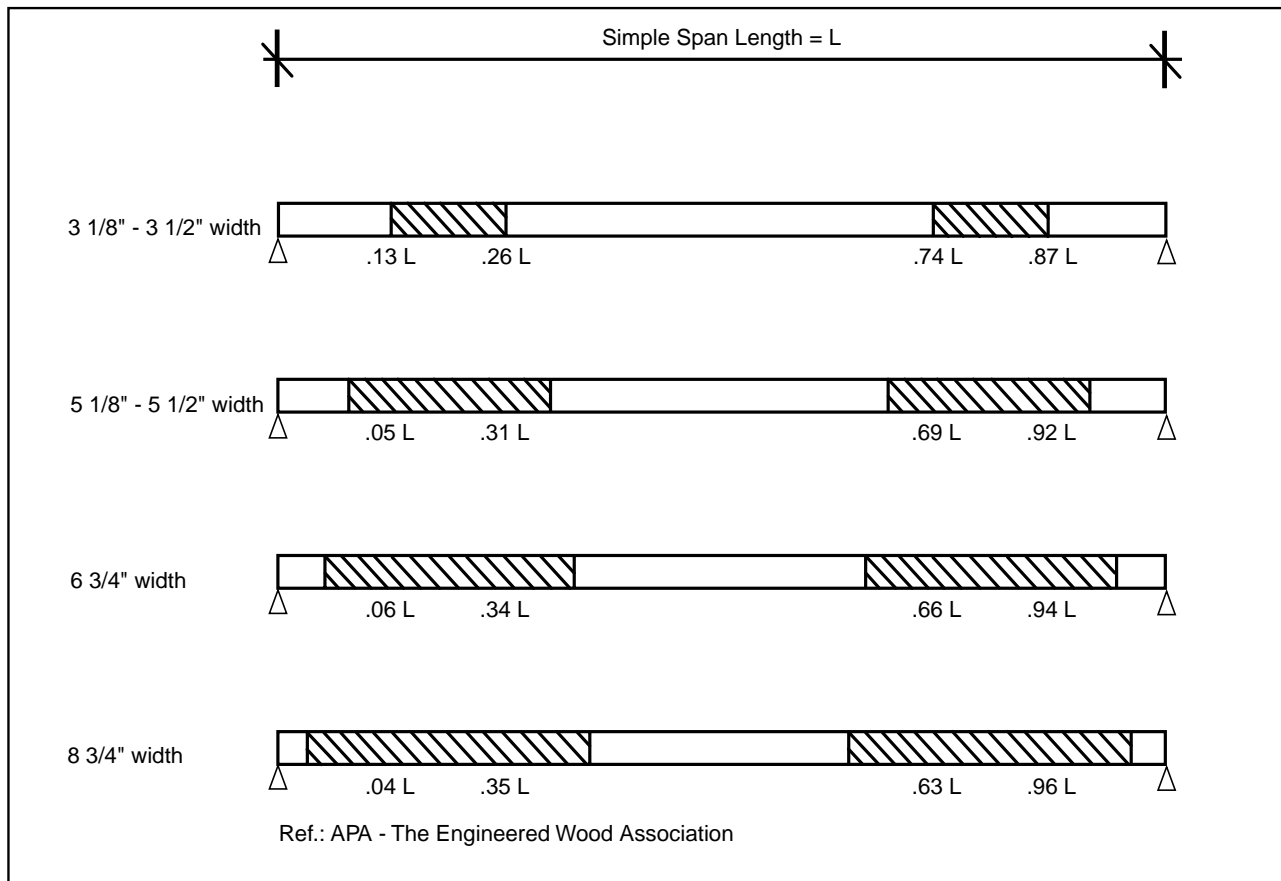
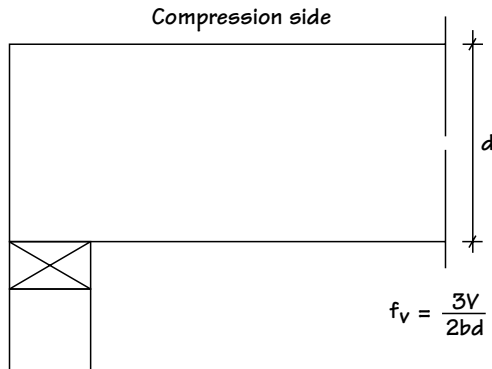

Figure 2 is provided to illustrate the allowable location for these vertical, 1/2" diameter holes:



Shear Design Equations for Notched and Tapered Beams



(a) SQUARE END BEARING

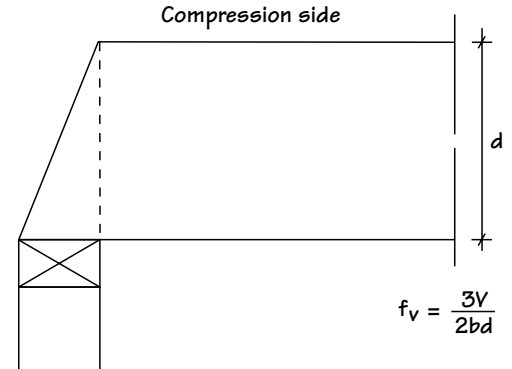

(b) SLOPED END BEARING

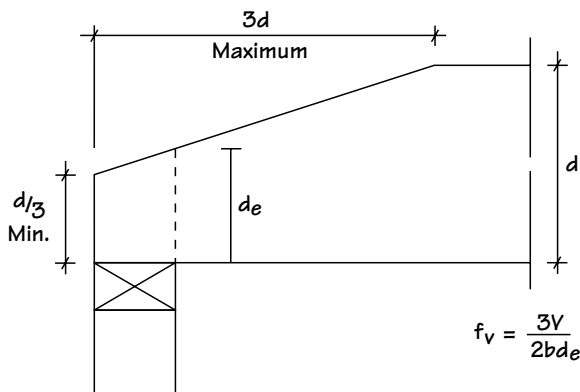

(c) SLOPED END CUT FOR ROOF DRAINAGE

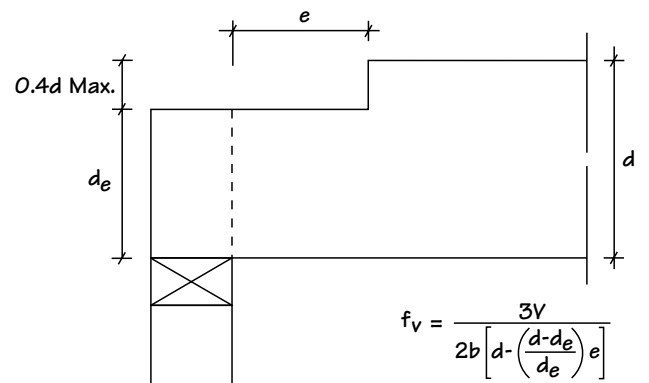

(d) COMPRESSION-SIDE NOTCH - WHERE $e \leq d_e$

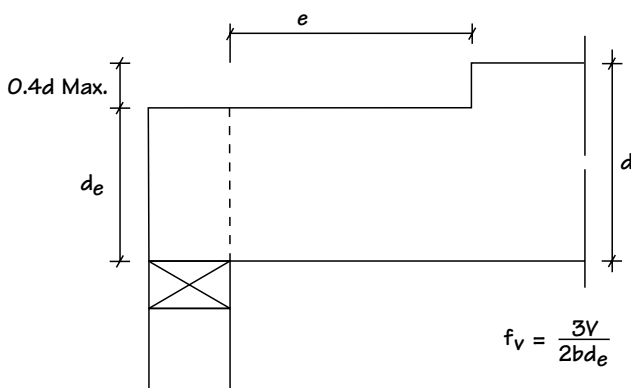

(e) COMPRESSION-SIDE NOTCH - WHERE $e > d$

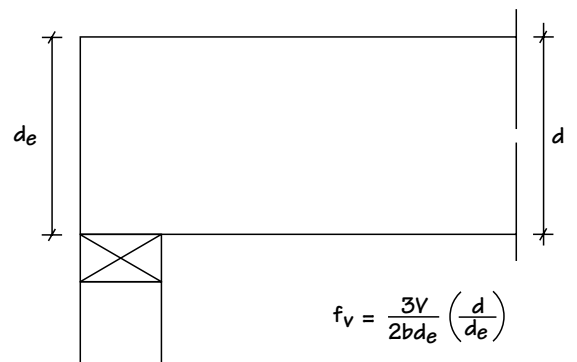

UNDER NO CIRCUMSTANCES SHOULD $d_e < 0.9d$

(f) TENSION-SIDE NOTCH - NOT RECOMMENDED

f_v = shear stress (psi), V = shear force at notch location (lb), b = width of beam (in.)
 d = depth of beam (in.), d_e = effective depth as shown (in.), e = length of notch as shown (in.)

Standard Radius or Curvature (feet)

Camber is the amount of bend or curvature which can be built into a Glulam to offset anticipated deflection or to compensate for dead load deflection. This is important for longer spans where other non-cambered engineered wood products may sag after loads are applied. A 1600-foot radius is most commonly referred to as standard camber. Anthony Forest's standard radius is 1600'; others indicated on this chart are available on request. Built-in camber will reduce ponding on flat roofs and eliminate unsightly appearance of deflection under load. Glulam is also offered non-cambered.

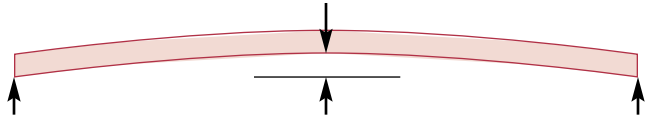

Camber Before Installation

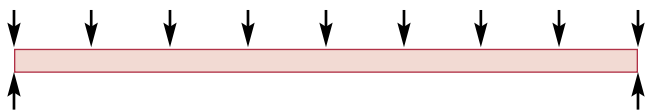

Camber After Installation With Roof and Wall Loads Applied
Without camber, a beam or header may sag after loads are applied.

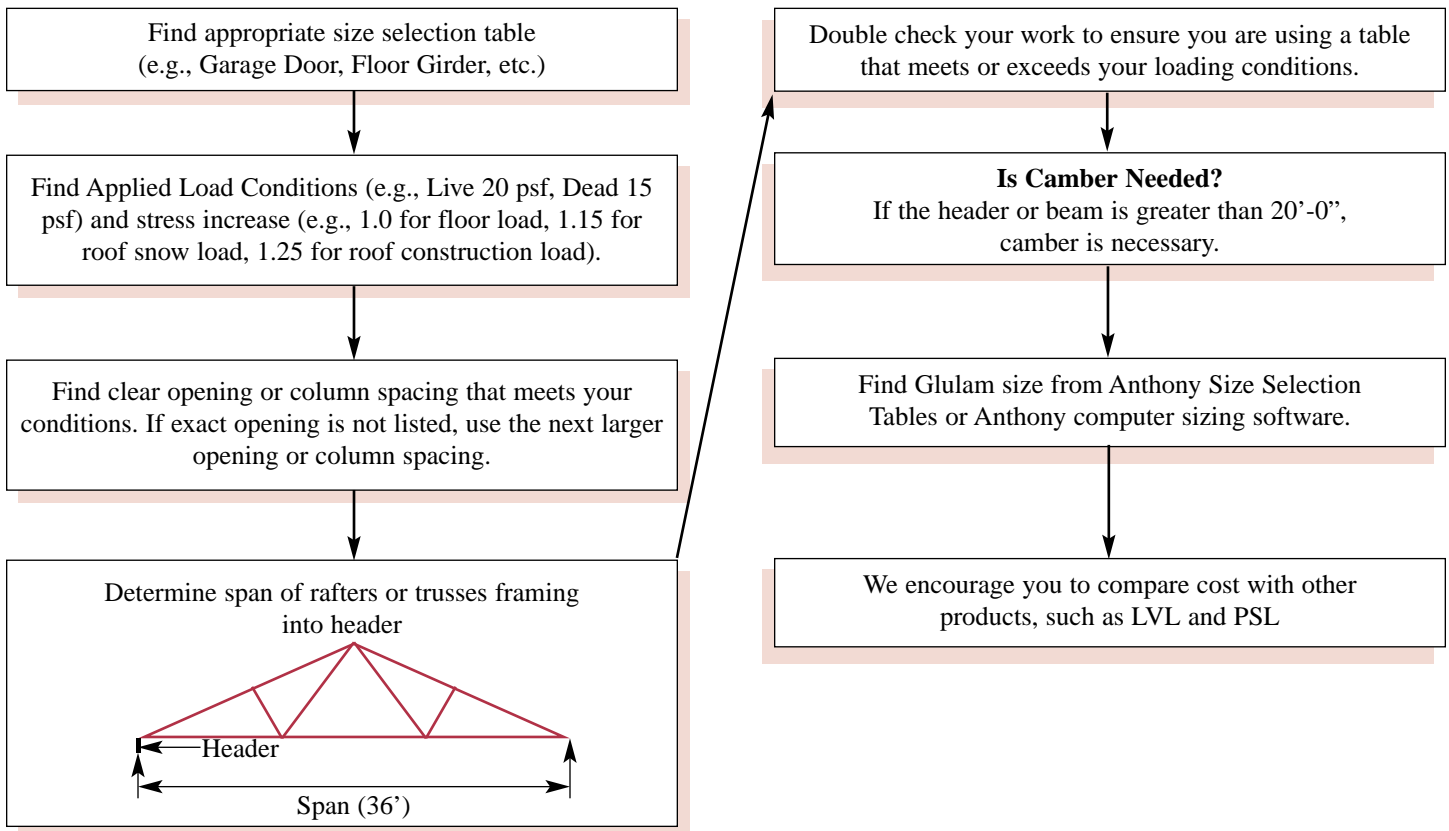

Camber is the amount of bend or curvature which can be built into a Glulam beam to offset anticipated deflection or to compensate for dead load deflection.

example: a 2000' Anthony Glulam beam at 12' allows 1/8" camber

		LENGTH							
		10	12	14	16	18	20	22	24
2000' Radius		1/8"	1/8"	1/8"	1/4"	1/4"	1/4"	3/8"	3/8"
		26	28	30	32	34	36	38	40
		1/2"	5/8"	5/8"	3/4"	7/8"	1"	1 3/8"	1 1/4"
		42	44	46	48	50	52	54	56
		1 3/8"	1 1/2"	1 5/8"	1 3/4"	1 7/8"	2"	2 1/4"	1 3/8"
		58	60						
		2 1/2"	2 3/4"						



ANTHONY®

POWER

COLUMN™

Anthony Power Column™ Features

- *Combination #50 (#1 Dense SYP)*
- *Architectural & Industrial Appearance*
- *Individually Wrapped*
- *3 1/8", 3 1/2", 5 1/8", 5 1/2", & 6 3/4" Widths*

Service and Support.....

- *National distribution through stocking dealers*
- *Comprehensive technical support literature*
- *AFP Sizer Software for designing beams and Columns*

Anthony Power Columns - Combination #50

Load Tables

Column Length	3-1/8 x 4-1/8				3-1/8 x 5-1/2				3-1/8 x 6-7/8				3-1/8 x 8-1/4			
	Concentric		Eccentric		Concentric		Eccentric		Concentric		Eccentric		Concentric		Eccentric	
	100%	100%	115%	125%	100%	100%	115%	125%	100%	100%	115%	125%	100%	100%	115%	125%
4'	19925	12651	13386	13783	33699	21135	22156	22679	42124	27095	28499	29227	51921	33563	35518	36562
6'	14716	9720	9921	10014	21186	15169	15377	15475	26482	19560	19851	19989	34513	25324	25794	26017
8'	9287	6845	6897	6922	12693	10233	10291	10320	15866	13119	13199	13239	20970	17255	17381	17443
10'	6142	4914	4934	4944	8288	7159	7182	7194	10360	9123	9154	9170	13740	12065	12113	12138
12'	4325	3656	3665	3670	5808	5228	5239	5245	7260	6633	6648	6656	9643	8794	8816	8828
14'	2590	2235	2240	2242	3474	3173	3179	3182	4342	4019	4026	4030	5770	5331	5343	5349
Column Length	3-1/2 x 3-1/2				3-1/2 x 4-1/8				3-1/2 x 5-1/2				3-1/2 x 6-7/8			
	Concentric		Eccentric		Concentric		Eccentric		Concentric		Eccentric		Concentric		Eccentric	
	100%	100%	115%	125%	100%	100%	115%	125%	100%	100%	115%	125%	100%	100%	115%	125%
4'	19474	11698	12325	12662	22951	14373	15249	15730	39753	24311	25636	26344	49629	31224	33064	34060
6'	15935	9045	9235	9322	18781	11576	11892	12040	28233	18790	19149	19316	35291	24472	24996	25242
8'	10741	6510	6553	6574	12659	8497	8576	8614	17527	13236	13334	13382	21909	17183	17324	17393
10'	7223	4755	4770	4778	8512	6242	6271	6286	11545	9481	9519	9538	14432	12224	12278	12306
12'	5115	3592	3599	3602	6029	4719	4733	4740	8118	7028	7046	7056	10148	9007	9032	9045
14'	3796	2798	2802	2804	4474	3672	3679	3683	6004	5381	5391	5396	7505	6863	6877	6884
Column Length	5-1/8 x 5-1/2				5-1/8 x 6-7/8				5-1/8 x 8-1/4				5-1/8 x 9-5/8			
	Concentric		Eccentric		Concentric		Eccentric		Concentric		Eccentric		Concentric		Eccentric	
	100%	100%	115%	125%	100%	100%	115%	125%	100%	100%	115%	125%	100%	100%	115%	125%
6'	57684	26099	33393	34044	72105	42822	44895	45978	88139	54057	57127	58786	102829	64224	68068	70164
8'	46657	20410	26556	26765	58321	35887	36727	37118	74000	47052	48556	49273	86334	56385	58329	59262
10'	33833	16036	20563	20634	42292	28432	28732	28874	55139	38198	38760	39025	64392	45875	46606	46953
12'	24562	12820	16102	16135	30702	22397	22531	22597	40473	30370	30616	30737	47219	36405	36723	36879
14'	18415	10440	12855	12873	23019	17873	17944	17980	30466	24304	24432	24496	35543	29046	29209	29291
16'	14257	8645	10460	10471	17821	14498	14540	14562	23631	19719	19793	19830	27569	23493	23587	23634
18'	11342	7265	8658	8665	14177	11949	11976	11990	18819	16236	16282	16306	21955	19290	19348	19378
20'	9228	7265	7274	7279	11536	9992	10010	10019	15323	13557	13588	13603	17876	16069	16106	16126
22'	7127	5690	5696	5699	8909	7804	7817	7824	11836	10581	10603	10614	13809	12528	12555	12568
24'	6098	4422	4424	4425	7623	1951	1954	1956	10128	2645	2651	2653	11815	10720	10742	10754
Column Length	5-1/2 x 5-1/2				5-1/2 x 6-7/8				5-1/2 x 8-1/4				5-1/2 x 9-5/8			
	Concentric		Eccentric		Concentric		Eccentric		Concentric		Eccentric		Concentric		Eccentric	
	100%	100%	115%	125%	100%	100%	115%	125%	100%	100%	115%	125%	100%	100%	115%	125%
6'	63425	34785	36224	34044	79281	46468	48822	50073	96468	58592	62042	63932	112547	69645	73974	76369
8'	53913	28700	29275	26765	67391	39791	40890	41408	84535	52106	54059	55012	98624	62593	65145	66403
10'	40663	22750	22939	20634	50828	32222	32622	32808	65887	43467	44249	44615	76868	52477	53518	54006
12'	29946	18015	18093	16135	37433	25741	25915	25999	49201	35190	35528	35691	57401	42466	42915	43132
14'	22579	14480	14519	12873	28224	20750	20841	20886	37298	28506	28680	28766	43514	34310	34538	34651
16'	17527	11840	11862	10471	21909	16967	17020	17047	29026	23335	23435	23485	33864	27996	28126	28192
18'	13965	9837	9851	8665	17456	14075	14109	14126	19876	19346	19408	19440	27017	23137	23218	23259
20'	11373	8290	8300	7279	14216	11834	11856	11868	16618	16241	16282	16303	22021	19369	19421	19448
22'	9435	7075	7082	5699	11794	10070	10086	10094	14068	13795	13823	13838	18279	16410	16445	16464
24'	7418	3007	3010	1425	9273	4280	4286	4290	5979	5863	5875	5881	14372	6974	6989	6997
Column Length	6-3/4 x 6-7/8				6-3/4 x 8-1/4				6-3/4 x 9-5/8				6-3/4 x 11			
	Concentric		Eccentric		Concentric		Eccentric		Concentric		Eccentric		Concentric		Eccentric	
	100%	100%	115%	125%	100%	100%	115%	125%	100%	100%	115%	125%	100%	100%	115%	125%
8'	94495	51460	53338	54283	115619	67251	70470	72162	134889	81145	85440	87730	154159	94735	100072	102947
10'	81256	43783	44631	45021	102227	59569	61349	62196	119265	72862	75369	76579	136303	85772	88988	90554
12'	64548	36292	36636	36794	83455	50886	51692	52064	97364	62754	63929	64476	111273	74200	75732	76449
14'	50217	29990	30151	30228	65821	42782	43171	43355	76792	52906	53481	53755	87762	62595	63347	63706
16'	39537	24986	25074	25116	52142	35993	36207	36311	60832	44496	44814	44969	69523	52574	52989	53192
18'	31735	21048	21101	21127	41981	30492	30623	30688	48977	37626	37820	37916	55974	44362	44612	44737
20'	25958	17928	17963	17980	34399	26058	26143	26187	40132	32071	32197	32261	45865	37722	37883	37965
22'	21595	15431	15454	15466	28648	22466	22525	22555	33422	27570	27657	27701	38197	32349	32459	32516
24'	18230	13407	13424	13432	24202	19533	19576	19598	28235	23899	23961	23992	32269	27978	28055	28095

NOTES:

- Table applies to solid, one piece column members used in dry service conditions.
- For eccentric conditions, loads have been adjusted for the worst case eccentric loading of 0.167 of the column thickness or 0.167 of the column width.
- Loads are based on axial loads in accordance with the 1997 National Design Specifications for Wood Construction. For side loads or other combined bending and axial load conditions, see the appropriate provisions of the '97 NDS.
- Columns are unbraced except at the column ends and the effective column length is equal to the actual column length.
- Column equation adjustments have been made for coefficient of variation (COV) of 0.15 for columns with 3 to 5 laminations, and 0.10 for columns with 6 to 8 laminations.

COMBINATION #50 ALLOWABLE DESIGN PROPERTIES (LDF=1.0)

Modulus of Elasticity, $E = 1.9 \times 10^6$ psi
 Flexural Stress, $F_b = 2100$ psi (Bending about X-X Axis)
 $F_b = 2100$ psi (Bending about Y-Y Axis, 3-1/2" & 4-1/8" depths)
 $F_b = 2300$ psi (Bending about Y-Y Axis, 5-1/2" & 11" depths)
 Compression Parallel to Grain, $F_c = 1700$ psi (3-1/2" & 4-1/8" depths)
 $F_c = 2300$ psi (5-1/2" & 11" depths)

Anthony 24F Glulam

Engineered Timbers

...offer versatility, economy, strength, and durability

Versatility

Anthony glued laminated timber has a proven track record of reliability for a variety of structural applications. Exposed beams offer a dramatic design element, yet provide an unusual sense of softness, natural charm, and inviting warmth.

At the same time, engineered timber construction provides an exceptionally high level of safety, durability and cost efficiency. Kiln-dried Anthony Glulam offer a strong, workable long span performance capability unmatched by any other building material.

Cost Effective/Energy Efficient

Anthony Glulam is surprisingly economical as compared to the higher cost composites or steel. The Glulam has a high strength to weight ratio and is sized to fit all system-type framing applications. One piece construction reduces building time and cost, and the Glulam can be trimmed to fit on the job site.

The energy efficiency of engineered timber can provide additional savings to the property owner. The natural thermal and insulating qualities of laminated wood can be combined with thermally efficient insulation materials to keep heat loss at a minimum.

Strong, Durable, Fire Safe, and Stable

Throughout history, wood has been a durable building material, assuming proper principles of design, construction, and maintenance are followed. The Anthony Glulam provides an even higher degree of proven quality manufacturing.

Both the 2400F and 3000F Power Beam exhibit property characteristics superior to solid sawn wood. Extra precautions are taken to ensure all laminations are kiln-dried to a maximum 15% moisture content.

The end product results in a beam member with an exceptional level of dimensional stability, virtually eliminating checking, twisting, warping, and shrinkage.

High resilience allows Glulams to absorb shocks that could rupture alternative building materials like concrete or steel. Glulam is also ideal for use in areas subject to high winds or earthquake damage. Glulam also has excellent fire-resistive qualities. The performance of Glulam under fire conditions is markedly superior to most unprotected non-combustible materials.

Readily Available

The Anthony Glulam is readily available through a network of stocking distributors throughout the country. Glulams are offered in specified lengths up to 60' in industrial, architectural, and premium grades. All beams are either bundled or individually wrapped with water-resistant paper. Beams are squared-end trimmed and manufactured with a standard 2000' radius camber or no-camber.

Computer Software

Anthony Forest offers a Windows friendly sizing software for fast and accurate sizing of most beam applications.

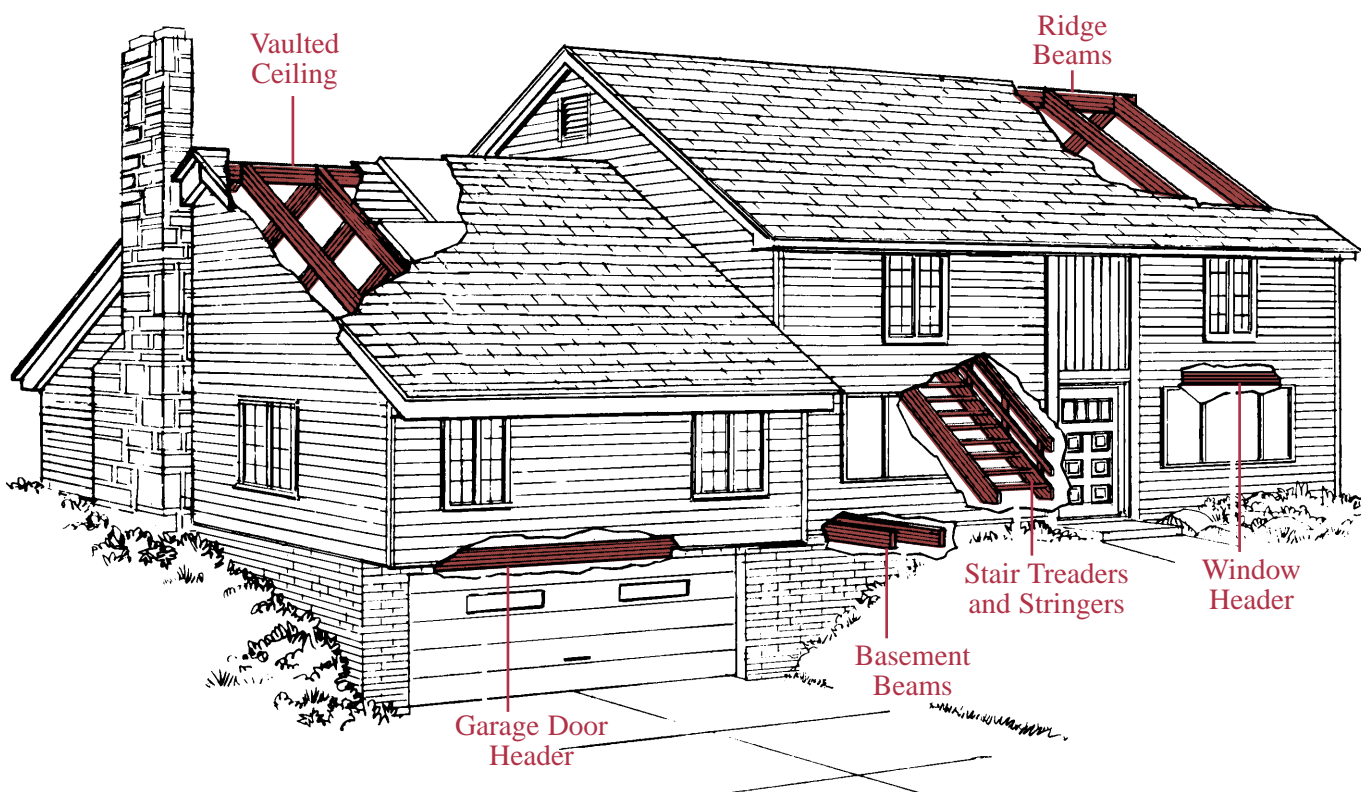

Power Products Storage Protection and Handling Instructions

Glued laminated wood materials like Anthony Power Products are a specialized product manufactured to designed strength and appearance standards. As with other building products, however, wood can be affected by the care – or lack of care – used during storage. Proper handling is important to insure that glued laminated wood material retain both the structural and appearance standards intended by the designer and built into the product at the plant. Following these simple precautions will help you obtain the kind of installation of which we can both be proud.

Unloading

If damage or loss in transit exists, do not unload until the delivering carrier has made an inspection. The carrier will not accept a damage claim unless its own inspection report accompanies the claim. Describe damage or loss in writing and file your written claim with the carrier. At the same time notify our sales office.

Material sold F.O.B. railcars or truck requires unloading by you. Use sufficient manpower and proper equipment. Tally quantities against material list. Do not drop or drag laminated materials. Use care in handling to prevent damage to finished surfaces; nylon or plastic slings are desirable.

Storage

The customer is responsible for protection of this material at all times after arrival. *Dimensional changes occur in wood with changes in moisture content.*

Product Handling & Protection

It is the responsibility of the buyer to request the shipper to tarp a truck. Schedule delivery and installation of glue laminated wood members to avoid extended yard or jobsite storage.

Keep Power Products as dry as possible during delivery, storage, handling and erection. If yard storage is necessary, place members on blocking away from ponding water or store under shed.

Proper yard and jobsite protection of Power Products is essential in maintaining dimensional stability. *The Power Beam® at I-joist compatible depths makes it ever more important to keep dry.* All Power Products are manufactured with a moisture content that averages 12%. As a general rule, for every 4% increase or decrease in MC, the beam will increase or decrease in size by 1%. Anthony Forest Products Company cannot be held responsible for physical changes that may occur as the result of constant exposure

to the elements and/or pressure preservative treated Power Products. These changes (severe checking, splitting, cupping and warping) may occur if beams are not properly protected from exposure to the elements.

Time of removal of factory wrapping is optional, but, it must be emphasized that factory applied wrapping provides additional protection from damage in handling and in-transit only. If beams are wet and still in the wrap, it must be removed. Increases in width and depth will occur if wrap stays on. If further utilization of the wrap is desired for protection after shipment, the members should be inspected and provided with additional protection as necessary. If it is impractical to replace wrapping, all of it should be removed. Do not leave members partially exposed due to potential sun bleaching. Do not allow moisture to accumulate inside wrapping. When you must store Power Products at the job-site, use the same care as with other mill work. Place on blocks well off the ground, separate with stripping in a vertically aligned position so air circulates around all four sides of each member and cover top and all sides with moisture-resistant paper, tarps or black polyethylene.

Erection

On unbalanced and cambered beams, there is a top and bottom of a beam. The top is always the narrow face where protective paper is folded and stapled. The top face will also have “TOP” stamped on the beam. Always place top towards the ceiling. If wrappings are removed temporarily at connections, replace them securely. After members are erected, if wrapping is to be left on, it is recommended that the wrapping paper be slit on the bottom or soffit face in several places along the member length to prevent water from being entrapped in the paper.

Error or Defect

In case of fabrication error or material defects, immediately notify nearest sales office. Anthony Forest reserves the right to investigate and correct alleged errors and defects. Please call the sales office to notify of any problems.

Finally

Following these suggestions will help assure a satisfactory product and will assist us in maintaining our high standard of quality and customer product acceptance.

We appreciate the opportunity to furnish Anthony Power Products for your customers.



Power Products CERTIFICATE OF WARRANTY

Anthony 30F Power Beam[®], Anthony 24 F Glulam, Power Header[®], Power Column[™], Power Log[®] and Power Plank[®] are superior glued laminated products engineered for reliable, lower cost performance in industrial and residential uses. Anthony Power Products are manufactured under strict quality control procedures.

We guarantee our family of Power Products to be free from defects in design, materials and workmanship.

We guarantee prompt and courteous customer service. For a detailed copy of our limited lifetime warranty, call us at 1-800-221-BEAM.

We guarantee to pay for all reasonable repair or replacement costs if you have problems due to a defect in our Power Products.

Our family name is on all of our Power Products. We intend to live up to our reputation for quality and service. We appreciate your confidence and your business.



John Anthony, President

Laminated Structural Products from Anthony Forest Products Company

Our choices of manufactured structural building products can have an impact on our environment and our consumption of energy. It is important to note that wood products have many advantages over aluminum, steel and concrete which are energy intensive to produce.

Glulam production uses a readily available and renewable resource of narrow dimension lumber from second and third growth timber as its raw material. Computer technology and advanced manufacturing processes enable the end-product to optimize fully our raw material. As a construction material, wood requires very little energy to manufacture, and is 4 times more efficient as an insulator than cinder block, 6 times more efficient than brick, 15 times more efficient than concrete and 1,770 times more efficient than aluminum.

For more information on Glulam, or other laminated structural products from Anthony Forest Products Company please call 1-800-221-2326 or FAX at 870-862-6502 or call your local dealer:

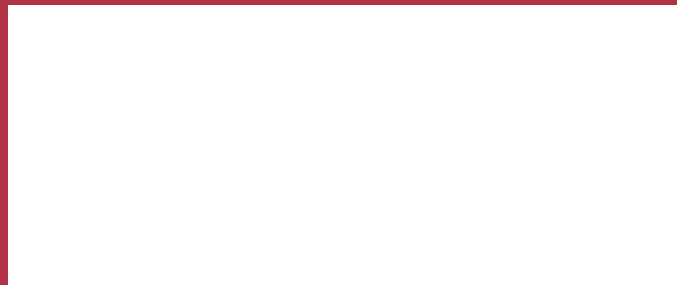

Anthony Forest Products Company

Post Office Box 1877 • El Dorado, Arkansas 71731

E-mail: info@anthonyforest.com • Website: <http://www.anthonyforest.com>

© 2001 Anthony Forest Products Company



BE CONSTRUCTIVE™

WOOD